



MKT V-5E_{sc}

INSTALLATION GUIDE

Please read through the instructions thoroughly before performing any of the steps. This guide is for all units produce prior to 180703E

MKT V-5Esc OPERATING, MAINTENANCE AND SERVICE MANUAL



Prior to the use of this equipment everyone that will be or will assist in the operation of this equipment must read and understand the MKT V-5Esc Operating, Maintenance and Service Manual. Failure to read and understand the MKT V-5Esc Operating, Maintenance and Service Manual will result in property damage, severe injury or death.

SAFETY INSTRUCTIONS

The following signal words will be found in this guide and may also be found in the MKT V-5Esc Operation, Maintenance and Service Manual. These words are intended to alert the operator(s) to a hazard and the degree of severity of the hazard.



Indicates a hazardous situation which, if not avoided, will result in death or serious injury.



Indicates a hazardous situation which, if not avoided, could result in serious injury.



Indicates a hazardous situation which, if not avoided, could result in minor injury or moderate injury.

NOTICE

Indicates a property damage message.

EXCAVATOR STICK PREPARATION

The bucket will need to be removed prior to vibratory hammer installation.

Maximum Stick Width 16.5 inches

Minimum Pin Diameter 80mm

Maximum Pin Diameter 100mm



HAMMER TO STICK ALIGNMENT

Place hammer with the manifold on the right of the stick facing the machine.



The stick pin will go to the top and the H-link pin will go to the bottom

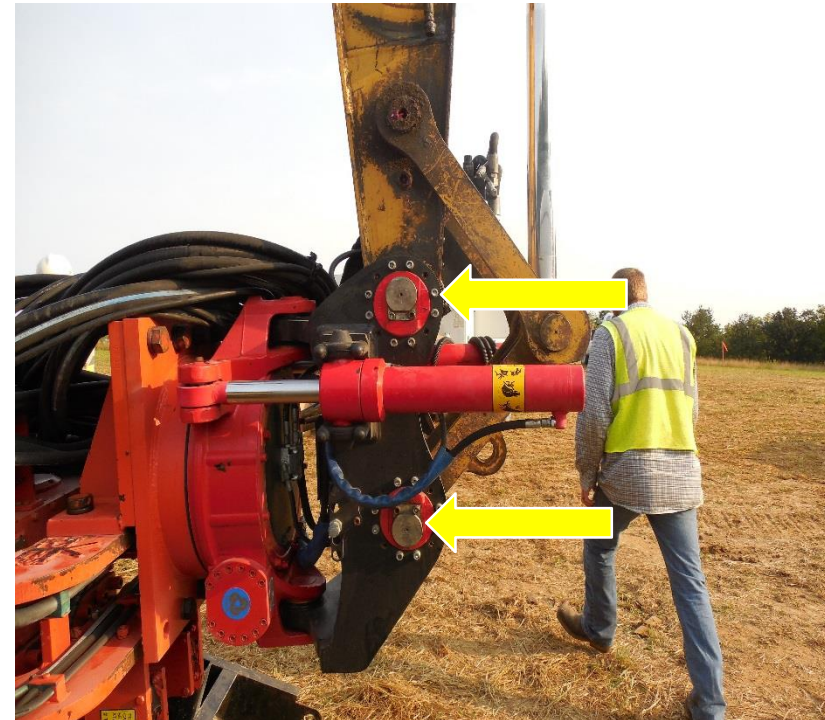

ADD SPACERS TO THE PINS AS
NEEDED

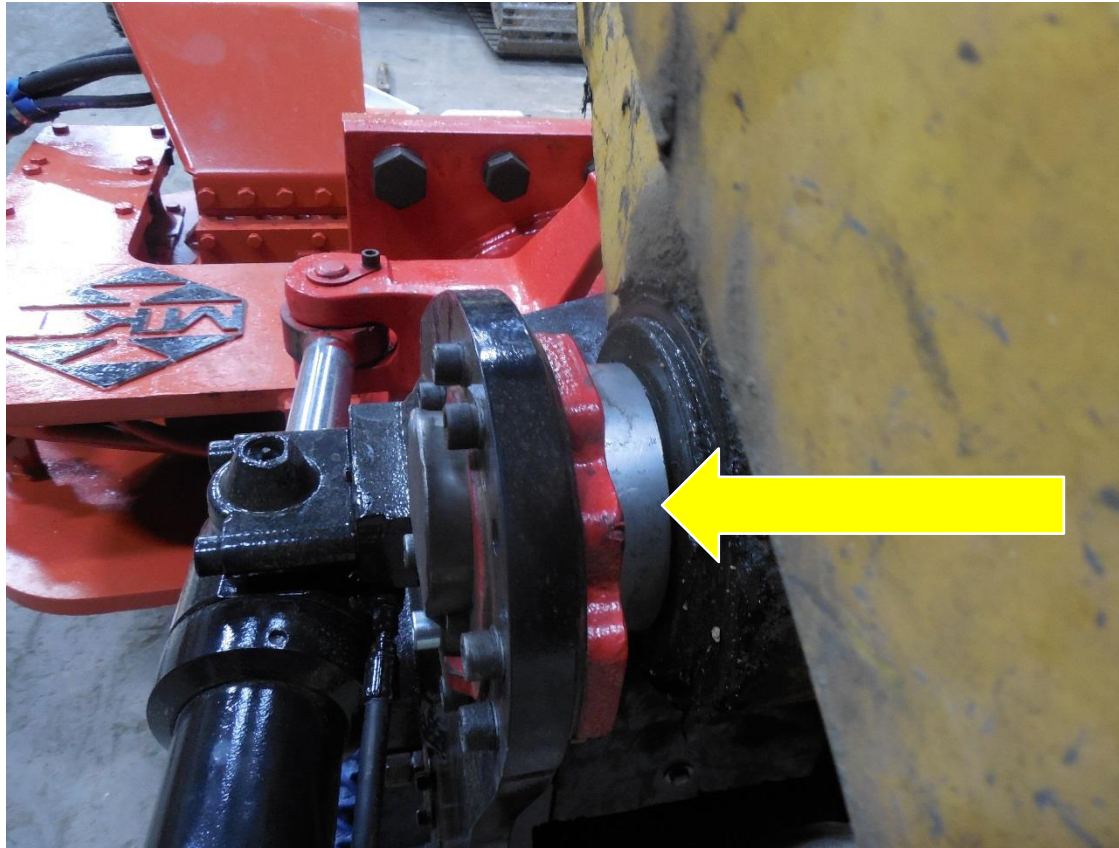

PLACE ELECTRICAL STAND ON THE EXCAVATOR

The electrical stand comes with magnetic feet. You will need to place the stand on a flat metal surface.



RUN THE 3 ELECTRICAL CORDS DOWN THE BOOM

The three cords that go down the boom are the green and yellow cord and the Ten pin rototilt control cable

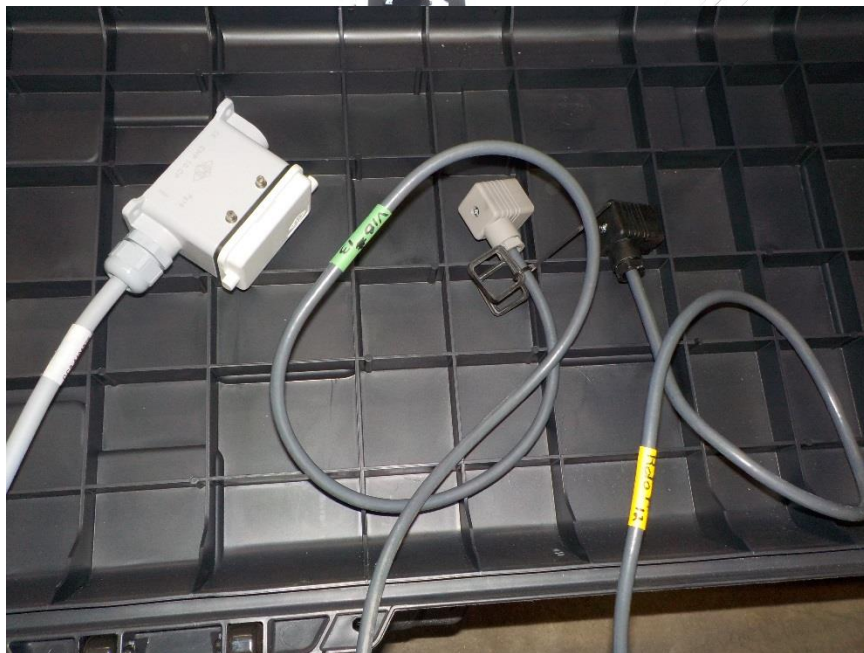

POWER SUPPLY

Red cable is for 24v supply. White is positive, black is negative and needs to be connected to a 24v power supply



AUXILIARY CONTROL CIRCUIT

The Blue cable is to be used to control the auxiliary circuit on the excavator. Due to the wide range of excavator controls, please contact your local excavator dealer for your brand of excavator. This is a 24v signal and white is positive and black is negative. If your system is negatively switched, you will need a relay in-line for our auxiliary control to control your system. Please refer to the next slide for an example of this connection.

NOTICE

If you have any questions please contact your local MKT representative.

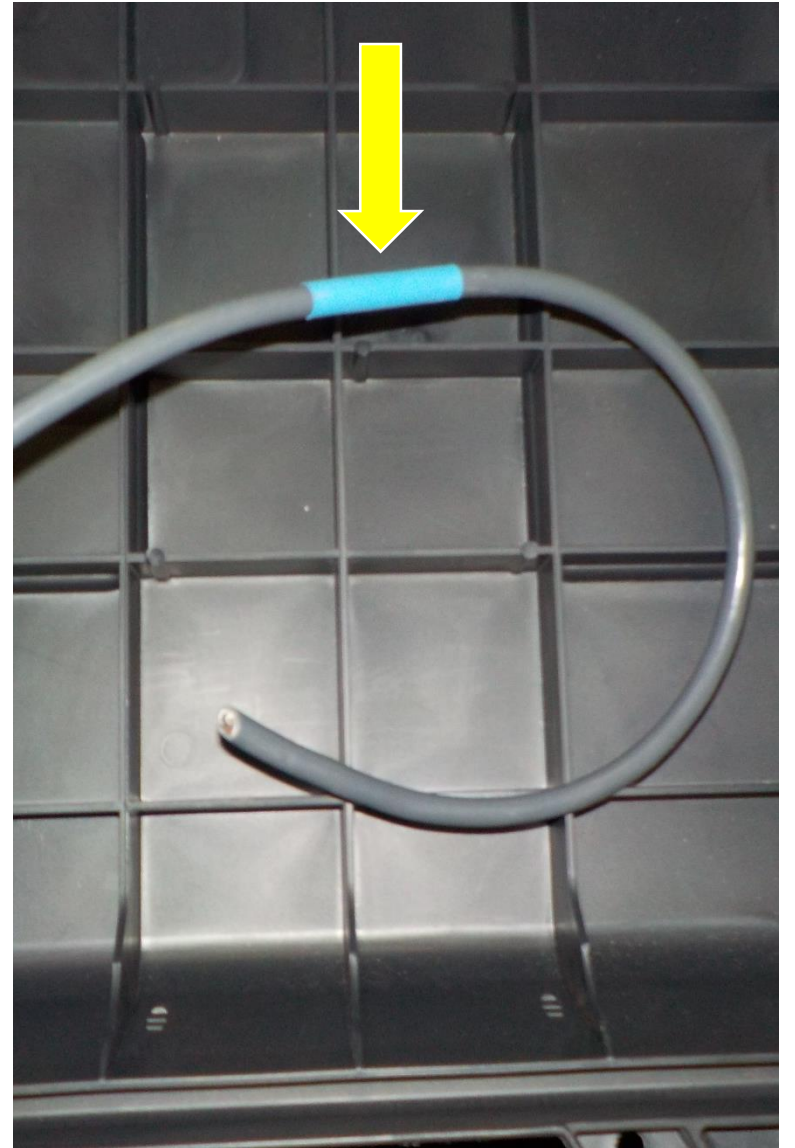

THIS IS AN EXAMPLE OF HOW TO PUT A RELAY INLINE TO CONTROL A NEGATIVELY SWITCHED CIRCUIT ON A CATERPILLAR 336F

The Blue Auxiliary control cord from the MKT junction box is connected to the relay with black wire to the negative terminal #85 and the white wire to the positive terminal #86

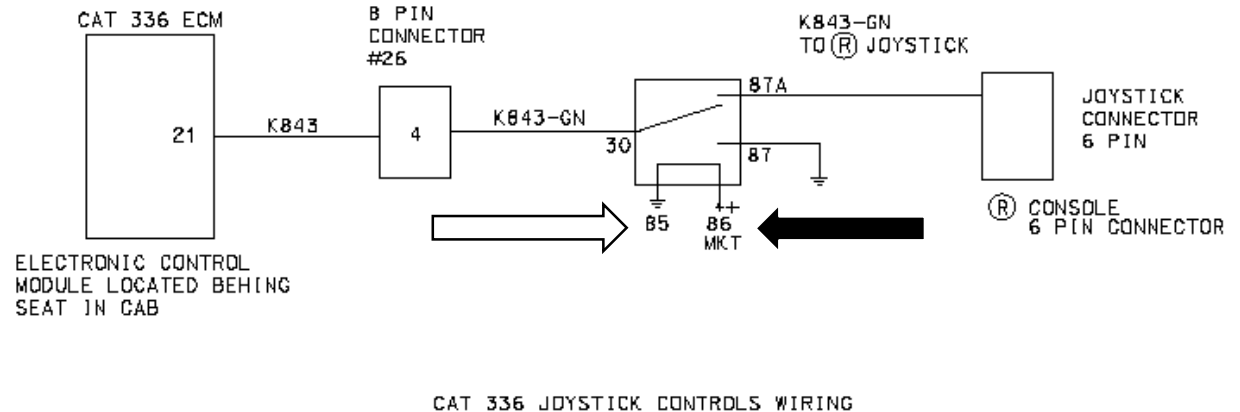

GREEN CORD #13

Connect the Green cable with the grey electrical connector labeled "A" to the solenoid stamped #13 on the manifold block.



YELLOW CORD #12

Connect the yellow cord with the black connector labeled "B" to the solenoid labeled #12 on the manifold

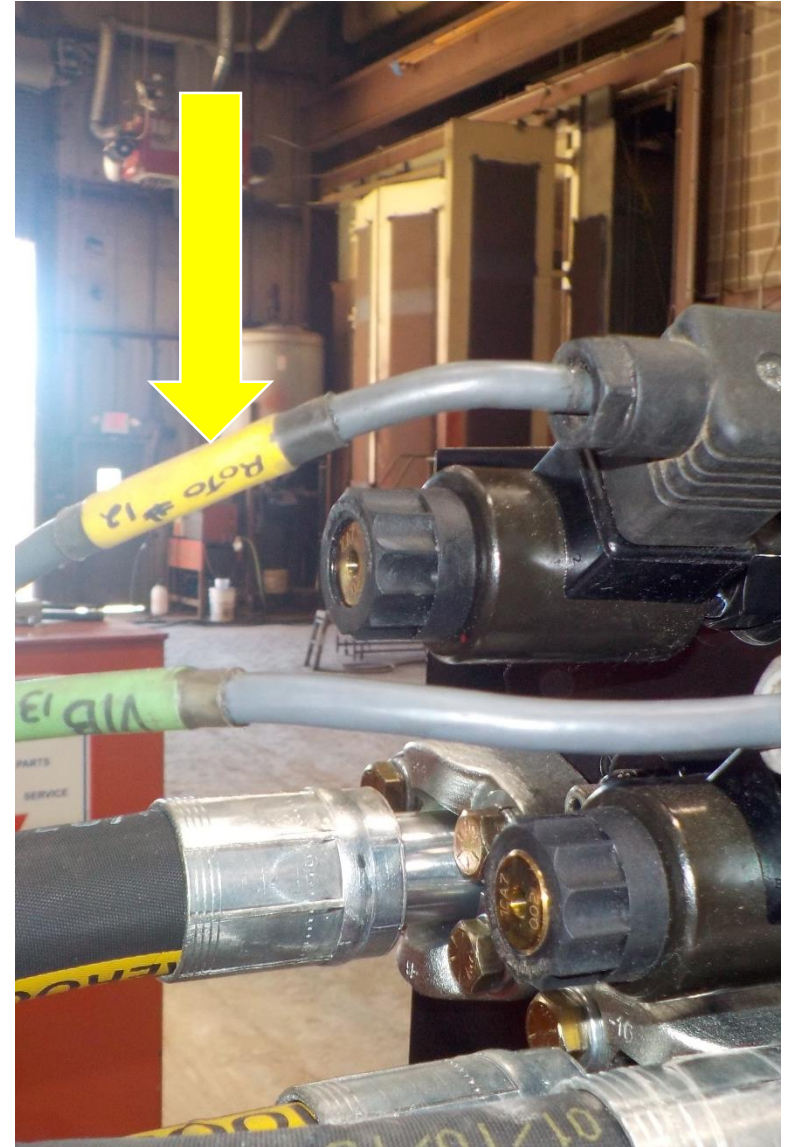

ROTOTILT CONTROL CABLE

Connect the boom cable to the rototilt control cable, these cables both have the 10 pin connector.



EXCAVATOR FLOW AND PRESSURE CHECK

- Before connecting to the MKT manifold you will need to activate the auxiliary circuit to verify the hydraulic flow path. A flowmeter works best for this. The MKT V-5Esc requires a flow of 90 gallons per minute with no back pressure. The auxiliary circuit needs a minimum pressure of 3500 psi.
- **NOTICE** Reversing the auxiliary circuit or applying flow to the manifold RETURN port will cause damage to the manifold's internal components.

HYDRAULIC CONNECTIONS

Once the direction of flow on the auxiliary circuit has been verified you can proceed with making the hydraulic connections as follows.

- Connect the Auxiliary supply circuit to the SUPPLY port on the manifold valve using a hose that is rated for the Excavators Maximum pressure capability.
- Connect the Auxiliary return circuit to the RETURN port on the manifold valve using a hose that is rated for the Excavators Maximum pressure capability.



CASE DRAIN LINE

Connect a $\frac{3}{4}$ inch drain line with a hydraulic hose rated for 100r1 or greater to the DRAIN port on the manifold valve. Route the hose back up the boom to the reservoir.

- **NOTICE** We need minimal restriction back to the hydraulic reservoir .
- **NOTICE** Failure to connect the Drain line to the hydraulic reservoir will cause damage to the internal components of the manifold and cause the vibratory motor to have a seal failure.



MKT V-5Esc OPERATING, MAINTENANCE AND SERVICE MANUAL



DANGER Prior to the use of this equipment everyone that will be or will assist in the operation of this equipment must read and understand the MKT V-5Esc Operating, Maintenance and Service Manual. Failure to read and understand the MKT V-5Esc Operating, Maintenance and Service Manual will result in property damage, severe injury or death.

 **DANGER** CLEAR THE AREA

Verify all personnel are clear of the vibratory hammer before proceeding to the next step.



POWERING UP THE CONTROLS

With the excavator running turn the power switch on the junction box to the ON position.

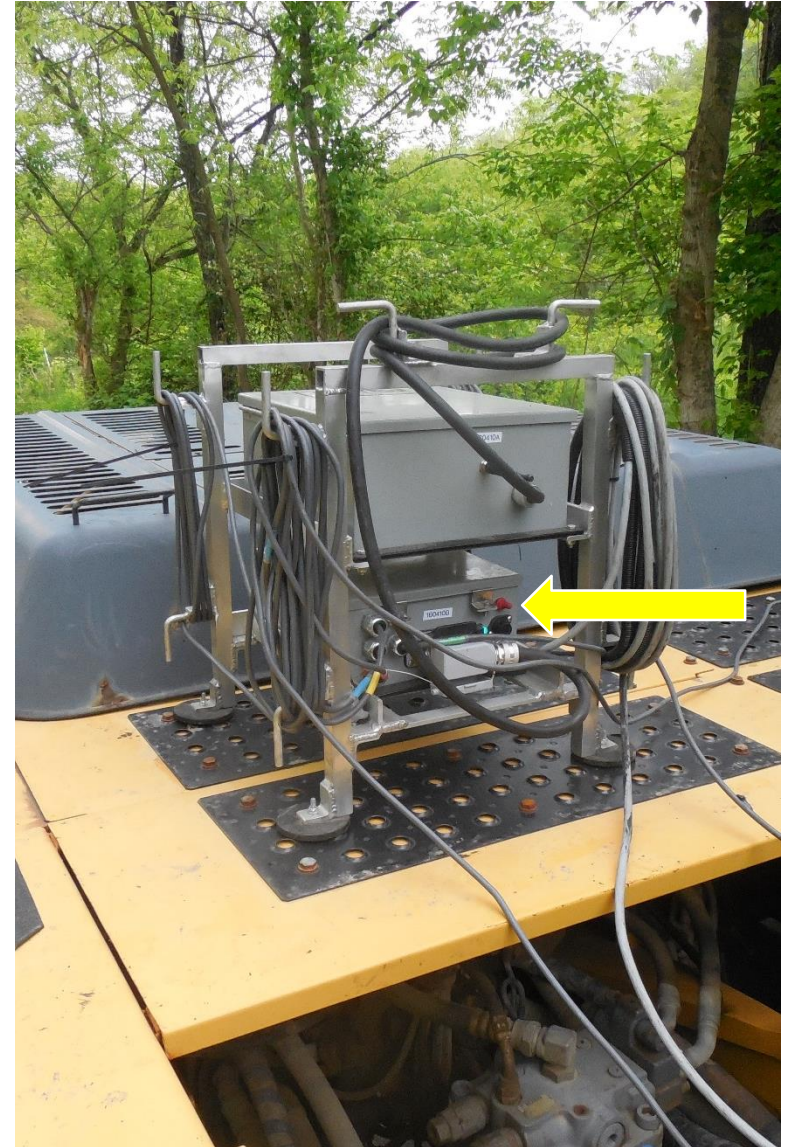

POWERING UP THE REMOTE

Once you have the junction box powered up you can push the on button in the upper left corner of the remote.

The power to the junction box has to be turned on before you can turn on the remote. [If you turn the remote on first the system will not recognize the remote.](#)

The remote has a timer built into it and if unused for 10 minutes it will shut off to save battery power.



OPERATION OF UNIT

Once you have followed the proper power up process you are now ready to start controlling the unit.

TILT function is controlled by pushing down on the top of the button to tilt left and the bottom of the button to tilt right.

Rotate function is controlled by pushing down on the top of the button to rotate left and the bottom of the button to rotate right.



OPERATION OF UNIT

Clamp function is controlled by first holding the button up or down on the PTO switch that is located directly to the right of the clamp function switch.

Once you have the PTO switch held you can now operate the clamp by pushing up on the clamp function button to open the clamps or down on the clamp function button to close the clamp.

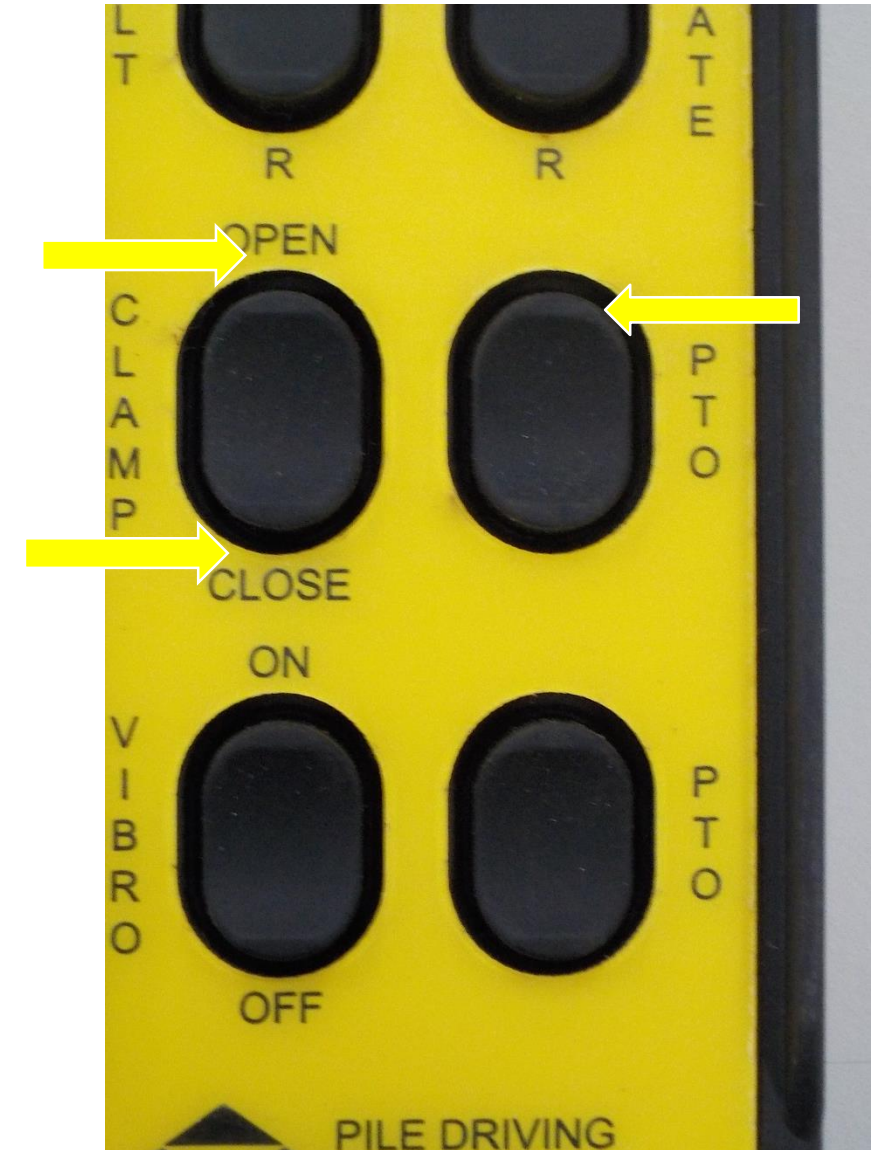

OPERATION OF UNIT

The vibratory function is controlled by first holding the button up or down on the PTO switch that is located directly to the right of the vibro function switch.

While you have the PTO held down you will need to push the Vibro switch up to the on position. The vibratory will continue to vibrate with out holding the buttons until you push the vibro function button down to the off position.

While turning the vibratory hammer off you will NOT need to push the PTO button

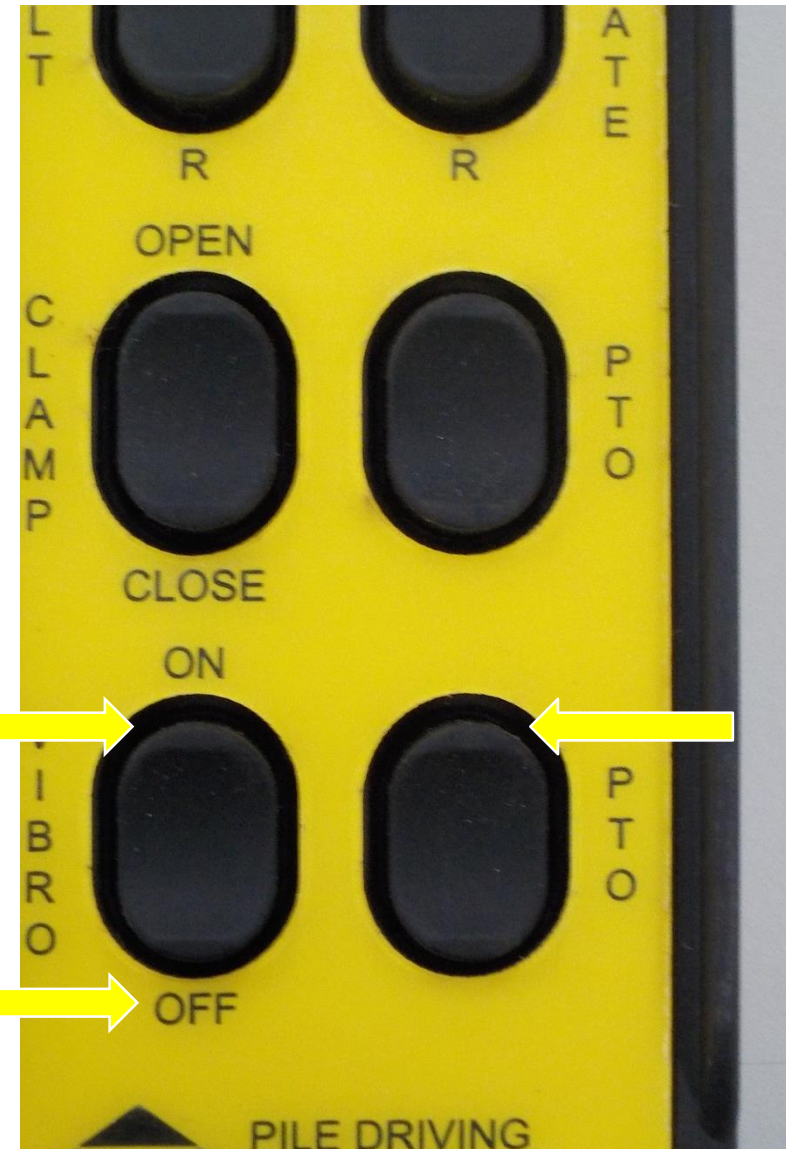

SETTING THE CYCLES OF THE MKT V-5Esc VIBRATORY HAMMER

You will need a photo-tachometer like the one in the photo below



Hold the laser or light beam from the photo-Tachometer on the bottom edge of the exciter case while the vibratory hammer is vibrating



ADJUSTING CYCLES



WARNING

To make following adjustments safely you will need to adjust the flow control cartridge on the manifold labeled #8 with the MKT V-5Esc not vibrating.

- Turning the set screw in will slow down the vibratory hammer.
- Turning the set screw out will speed up the vibratory hammer.
- When you have made the necessary adjustments, start the vibratory hammer and check the cycles as explained in the previous slide.
- Repeat the above steps until you obtain a speed between 1625 to 1675 cycles.

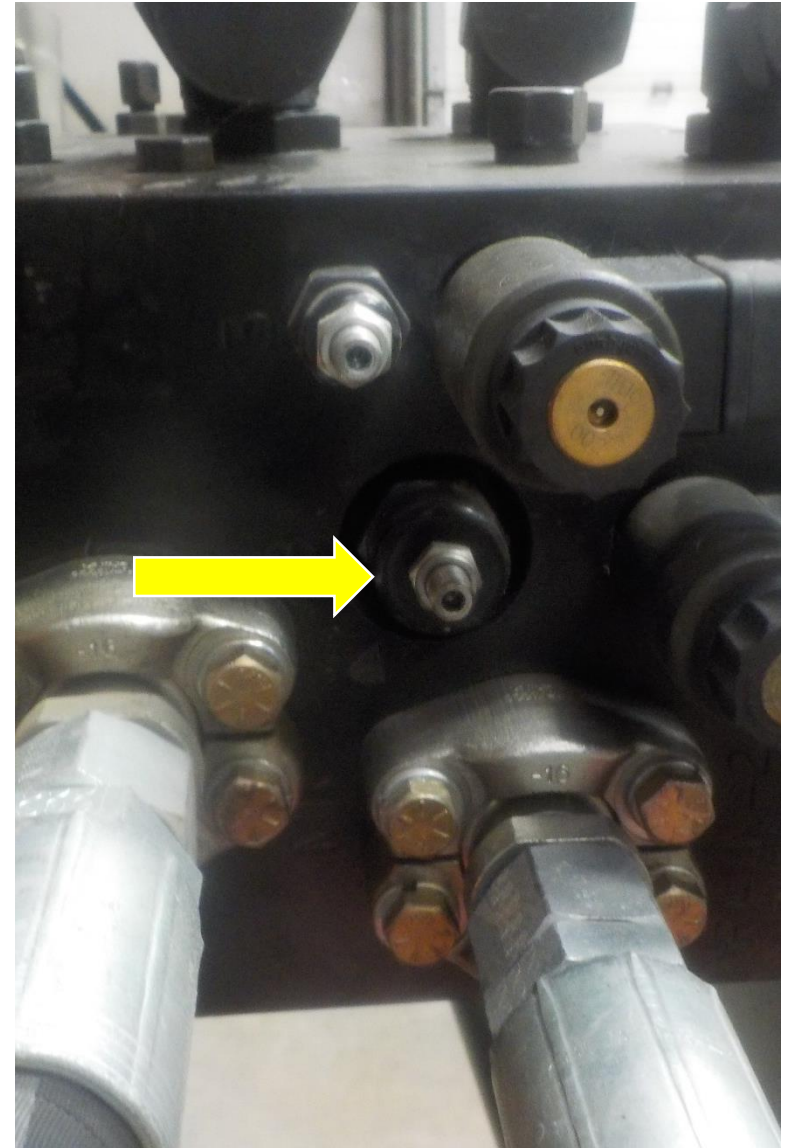

MKT V-5Esc OPERATING, MAINTENANCE AND SERVICE MANUAL



Prior to the use of this equipment everyone that will be or will assist in the operation of this equipment must read and understand the MKT V-5Esc Operating, Maintenance and Service Manual. Failure to read and understand the MKT V-5Esc Operating, Maintenance and Service Manual will result in property damage, severe injury or death.

INSTALLATION IS COMPLETE

You are now ready to put the MKT V-5Esc vibratory hammer to work. . If you have any questions please click on www.mktpileman.com for you nearest MKT representative.