



# MANUFACTURING, INC.

1198 PERSHALL RD.  
ST. LOUIS, MO 63137, USA  
Telephone: 314-388-2254  
Website: [www.mktpileman.com](http://www.mktpileman.com)

## PARTS, SERVICE, OPERATING AND MAINTENANCE MANUAL FOR THE V-8Esc HYDRAULIC VIBRATORY PILE DRIVER/EXTRACTOR SYSTEM



### WARNING

THIS PRODUCT MAY CONTAIN OR EMIT CHEMICALS SUCH AS DIESEL ENGINE EXHAUST AND SOME OF ITS CONSTITUENTS THAT ARE KNOWN TO THE STATE OF CALIFORNIA TO CAUSE CANCER, BIRTH DEFECTS, AND OTHER REPRODUCTIVE HARM.

### OCCUPATIONAL HEALTH WARNINGS:



1. Construction equipment frequently operates at very high sound levels. Such sound levels can be harmful to the human hearing system. Sustained exposure to such high sound levels can permanently impair one's hearing. **Hearing protection should be worn by anyone and everyone within close proximity to a Vibratory Pile Driver/Extractor System.**

2. Do not install, operate, or service the V-8Esc until having thoroughly read this manual and having received instructions from an MKT factory authorized service representative or properly trained, experienced operator. **Make this manual available to all persons responsible for the operation, installation, servicing and maintenance of this product. Also wear proper clothing and personal protection equipment such as, safety shoes, safety goggles, hearing protection and hard hat**

# **MKT MANUFACTURING, INC.**

## **STANDARD NEW PRODUCT WARRANTY**

### **EXPRESS LIMITED PARTS WARRANTY FOR NEW PRODUCTS**

MKT MANUFACTURING, INC. ("MKT") warrants to the first user ("User") of any new product (whether such new product is sold directly to the customer by MKT or through a distributor) that such new product will be free from defects in material or workmanship for a period of ninety (90) days beginning on the date that such new product is delivered to the User. This Express Limited Parts Warranty ("Warranty") applies only to the first User of the new product, and not any subsequent users, regardless of whether such subsequent user becomes the owner of the new product or uses the product within such ninety (90) day warranty period. In no event shall this Warranty extend for more than twelve (12) months from the date that MKT ships the product, whether to a User or to a distributor which may or may not use the product. This Warranty applies to new products only. This Warranty is subject to the following terms and conditions.

If User believes that the product has a defect in the materials or workmanship, User shall send notice of such defect in writing to MKT within the ninety (90) day warranty period. MKT shall have the right to inspect the product for defects, and any parts which appear to MKT upon inspection to have been defective in material or workmanship shall be repaired or replaced at MKT's option. MKT shall have no other liability to User except for such repair or replacement of those parts determined to be defective. Such repair or replacement parts shall be provided at no cost to the User at such location and during such hours as determined by MKT. This Warranty shall not apply to component parts or accessories of products not manufactured by MKT, or to normal maintenance of the product or to normal maintenance parts required therefor. Replacement or repair parts installed in the products covered by this Warranty are warranted only for the remainder of the Warranty as if such parts were original components of said product. **EXCEPT AS EXPRESSLY SET FORTH IN THIS WARRANTY, MKT MAKES NO OTHER WARRANTIES, AND FURTHER DISCLAIMS ALL OTHER WARRANTIES, EXPRESS OR IMPLIED, AND MAKES NO WARRANTY OF MERCHANTABILITY OR FITNESS FOR ANY PARTICULAR PURPOSE.**

**THIS WARRANTY IS NOT APPLICABLE TO ANY ITEM WHICH MKT SELLS THAT IS WARRANTED DIRECTLY TO THE USER BY THE MANUFACTURER OF SUCH ITEM (IF SUCH MANUFACTURER OF SUCH ITEM IS NOT MKT).**

**MKT EXCLUDES ALL LIABILITY FOR OR ARISING FROM ANY NEGLIGENCE ON ITS PART OR ON THE PART OF ANY OF ITS EMPLOYEES, AGENTS OR REPRESENTATIVES WITH RESPECT TO THE MANUFACTURE OR SUPPLY OF THE PRODUCT.**

MKT shall not be liable to User or any third party for any loss of profits, loss of use, interruption of business, or any indirect, incidental, special, punitive or consequential damages of any kind whatsoever related to the product or the use or operation of the product. In particular, MKT assumes no liability for the results of User and its affiliates based on User's use of the products furnished by MKT. The maximum total liability of MKT shall be limited to the cost of those parts which MKT has agreed to repair or replace. This limitation applies to all causes of action in the aggregate, including without limitation, breach of contract, breach of warranty, negligence, strict liability, misrepresentations, and other torts. In any jurisdiction in which the above limitations of liability are restricted, MKT's liability is limited to the greatest extent permitted by law.

Notwithstanding anything in this Agreement to the contrary, MKT shall not be responsible for any costs or charges of User and/or any third party, including but not limited to transportation charges, shipping costs, cost of installation, duty, taxes or any other charges whatsoever including but not limited to any charges or damages due to any delays. If requested by MKT, products or parts for which a warranty claim is made are to be returned transportation prepaid to MKT at MKT's home office. Any improper use, including operation after discovery of defective or worn parts, operation beyond rated capacity, substitution of parts not approved by MKT, or any alteration or repair by others in such manner as in MKT's judgment affects the Product materially and adversely, shall void this Warranty.

**NO EMPLOYEE OR REPRESENTATIVE IS AUTHORIZED TO CHANGE THIS WARRANTY IN ANY WAY OR GRANT ANY OTHER WARRANTY UNLESS SUCH CHANGE IS MADE IN WRITING AND SIGNED BY AN OFFICER OF MKT AT ITS HOME OFFICE.**



# TABLE OF CONTENTS

<b>I.</b>	<b>INTRODUCTION .....</b>	<b>2</b>
<b>II.</b>	<b>SAFETY INSTRUCTIONS.....</b>	<b>3</b>
<b>III.</b>	<b>SPECIFICATIONS.....</b>	<b>10</b>
<b>IV.</b>	<b>EXCAVATOR REQUIREMENTS.....</b>	<b>11</b>
<b>V.</b>	<b>SYSTEM SET-UP INSTRUCTIONS .....</b>	<b>12</b>
<b>VI.</b>	<b>START-UP PROCEDURES .....</b>	<b>16</b>
<b>VII.</b>	<b>OPERATING INSTRUCTIONS.....</b>	<b>21</b>
<b>VIII.</b>	<b>MAINTENANCE AND SERVICE INSTRUCTIONS .....</b>	<b>24</b>
	<b>A. V-8Esc DAILY CHECKLIST</b>	
<b>IX.</b>	<b>SERVICE TROUBLE SHOOTING.....</b>	<b>28</b>
<b>X.</b>	<b>DRAWING AND PARTS LISTS .....</b>	<b>30</b>
	<b>A. V-8Esc GENERAL ASSEMBLY AND PARTS LIST</b>	
	<b>B. EXCITER CASE ASSEMBLY</b>	
	<b>C. ECCENTRIC SHAFT ASSEMBLY AND PARTS LIST</b>	
	<b>D. MOTOT SHAFT ASSEMBLY AND PARTS LIST</b>	
	<b>E. V-8Esc HYDRAULIC CLAMP ASSEMBLY AND PARTS LIST</b>	
	<b>F. SIDE CLAMP ASSEMBLY</b>	
	<b>G. ROTOTILT ASSEMBLY</b>	
	<b>H. MANIFOLD ASSEMBLY</b>	
	<b>I. V-8Esc HYDRAULIC SCHEMATIC AND PARTS LIST</b>	
	<b>J. ELECTRICAL SCHEMATIC</b>	

## I. INTRODUCTION

This manual is exclusively for the MKT V-8Esc Hydraulic Vibratory Pile Driver/Extractor System. The manual for the Rototilt mounting system that attaches the V-8Esc to the excavator is included with this manual. **It is your responsibility to read and understand this manual, the Rototilt/Indexator manual, and the excavator manufacturer's manuals before operating this hydraulic construction tool. Make the following points part of your regular workday.**

- Know the limitations and operating characteristics of the Vibratory Pile Driver/Extractor System.
- Inspect the V-8Esc before each use as specified in this manual and by your employer.
- NEVER use attachments that are not approved by the manufacturer.
- NEVER remove or modify any parts of the equipment.
- Know the location of other personnel and equipment and make sure they are at a safe distance before operating.
- All visitors or other personnel in the immediate area of operating equipment must wear all necessary personal protective equipment.

The MKT V-8Esc Hydraulic Vibratory Pile Driver/Extractor System is used for installing or removing piling. The five major components of an MKT Vibratory Pile Driver/Extractor include rotating eccentric weights housed in a gear box that generate the vibratory forces to the pile, an elastomer suspension system to isolate the vibratory forces from the excavator, a bottom hydraulic clamp and side clamp system to grip the pile and Rototilt system to position the hammer.

There are four rotating eccentric weights in the V-8Esc mounted in special heavy duty spherical roller bearings. Two fixed displacement piston hydraulic motors are used to drive two of the eccentric weights. The other two eccentric weights are, in turn, gear driven and timed off the first two weights.

When operating within its load capabilities, the **V-8Esc** vibratory is designed to deliver a driving force of about **80 tons** to a pile at a rate of **2,250 vibrations per minute**.



## II. SAFETY INSTRUCTIONS

 **DANGER**

**FAILURE TO COMPLY WITH THE FOLLOWING SAFETY INSTRUCTION AND LOCAL REGULATIONS WILL RESULT IN PROPERTY DAMAGE, SEVERE INJURY OR DEATH.**

The following safety instructions are contained in the text of this manual. Read the entire manual before operating the hammer. Remember SAFETY IS UP TO YOU! Good safety practices not only protect you but also protect the people around you.





The following signal words will be found in this manual and may also be found in other manufacturer's manuals. These words are intended to alert the operator to a hazard and the degree of severity of the hazard.

 **DANGER** indicates a hazardous situation which, if not avoided, will result in death or serious injury.

 **WARNING** indicates a hazardous situation which, if not avoided, could result in death or serious injury.

 **CAUTION** indicates a hazardous situation which, if not avoided, could result in minor injury or moderate injury.

**NOTICE** indicates a property damage message.

- A.  **DANGER** For each lift the operator must review the excavator lifting capacity to determine that the weight of the hammer/ Rototilt assembly plus the load being lifted is within the rated capacity of the excavator.
- B.  **WARNING** Check that all personnel are clear of the V-8Esc unit prior to start up.
- C.  **DANGER** Keep hands clear of all three clamps at all times.
- D.  **DANGER** Always use pile handling/ safety line to attach the pile to the hammer.

- E. **⚠ DANGER** Leave the pile handling/ safety line attached to the pile at all times if the pile is not stuck securely in the ground.
- F. **⚠ DANGER** The V-8Esc side clamp attachment is designed to handle a single pile with a **MAXIMUM** weight of 2 tons. Appropriate pile handling rigging should be supplied by the end user to handle the pile in a safe manner. Attach safe handling cable(s) to lifting eye(s) on the hammer to allow for pile placement in the jaws as shown in figure 1.
- G. **⚠ CAUTION** Before closing the jaws of the bottom clamp, assure that the pile head is firmly against the clamp housing. Gripping the pile with merely the lower end of the jaws will damage the jaws, the clamp slide and/ or other clamp assembly components
- H. **⚠ DANGER** Stand a safe distance away from the pile and from below the V-8Esc hammer during vibrating operations. Any unobserved or unconnected, loose nut or other fastener may fall.
- I. **⚠ DANGER** Do not unclamp the jaws from the pile while the hammer is vibrating.
- J. **⚠ WARNING** Do not pull in excess of the rating of the V-8Esc hammer's suspension assembly or excess stresses will be put on the suspension assembly damaging one or more parts.
- K. **⚠ CAUTION** Whenever the V-8Esc hammer is observed “dancing or chattering” in place, it should be hoisted until the action stops. Failure to move a pile with the hammer “dancing or chattering” should be cause to promptly abandon the effort before serious damage is done to the hammer. To continue operations the obstruction must be removed or penetrated by switching to another driving system such as a larger vibro or a MKT diesel or air pile hammer.

## IMPORTANT SAFETY INFORMATION

Virtually all accidents that involve product operation, maintenance and repair are caused by failure to keep fundamental safety rules or precautions. An accident can often be avoided by identifying potentially unsafe situations before an accident occurs. A person must be alert to potential hazards. This person should also have the necessary training, skills and tools to perform these functions properly. Do not operate or perform any lubrication, maintenance or repair on this equipment until you have read and understand the applicable information in the Operation and Maintenance Manual.

MKT cannot anticipate every possible circumstance that might involve a potential hazard. The warnings in the manuals and on the equipment are therefore not all inclusive. If a tool, procedure, work method or operating technique not specifically recommended by MKT is used, you must satisfy yourself that it is safe for you and others. You should also ensure that the equipment will not be damaged or made unsafe by the operation, lubrication, maintenance or repair procedures you choose.

The information, specifications, and illustrations in the manuals are based on information available at the time it was written. The specifications, torques, pressures, measurements, adjustments, illustrations, and other items can change at any time. These changes can affect the service given to the product. Obtain the complete and most current information before starting any job. MKT and MKT distributors have the most current information available.

## GENERAL HAZARD INFORMATION

Use caution when removing filler caps, grease fittings, pressure taps, breathers or drain plugs. Hold a rag over the cap or plug to prevent being sprayed or splashed by liquids under pressure.

Wear a hard hat, protective glasses, hearing protection and other protective equipment as required by job conditions.

Do not wear loose clothing or jewelry that can catch on controls or other parts of the equipment.

Make certain all protective guards and covers are secured in place. Use all cleaning solutions with care.

Never put maintenance fluids into glass containers since glass containers can break.

Report all needed repairs.

**UNLESS INSTRUCTED DIFFERENTLY,  
PERFORM ALL MAINTENANCE AS FOLLOWS**

**Stop the hammer.**

**Refer to excavator operator manual to lockout the excavator auxiliary hydraulic circuit and electrical systems so they cannot energize while working on hammer.**

**Do not attempt any repairs or adjustments to the hammer while it is running.**

**Do not attempt repairs you do not understand. Use proper tools; replace or repair broken or damaged equipment.**

**Block or restrain the equipment, if applicable before operating or performing maintenance.**

**Do not adjust, or set, hydraulic pressures higher or lower than those specified in the manual.**

**PRESSURIZED AIR AND WATER**

**Pressurized air can cause personal injury. When using pressurized air for cleaning, wear a protective face shield, protective clothing and protective shoes.**

**The maximum air pressure must be below 30 psi (205 kPa) and maximum water pressure must be below 40 psi (275 kPa) for cleaning purposes.**

**FLUID PENETRATION**

**Wear eye protection at all times when cleaning the cooling system. Pressurized water could cause debris and/or hot water to be blown and result in personal injury.**

**Always use a board or cardboard when checking for a leak. Escaping fluid under pressure, even a pin-hole size leak, can penetrate body tissue, causing serious injury or possible death.**

**If fluid is injected into your skin, it must be treated by a doctor familiar with this type of injury immediately.**

## HOSES, LINES, AND TUBES

Do not pull on, or attempt to move equipment, with hydraulic hoses.

Do not operate this equipment with hydraulic hoses that are damaged or kinked. Replace damaged hoses immediately.

Do not lift, or support, hydraulic hoses with wire rope slings.

Do not pull kinks in the hoses. Kinks will reduce the hose safety factor by 50 percent.

Do not bend or strike high pressure lines. Do not install bent or damaged lines, tubes or hoses.

Repair any loose or damaged fuel and oil lines, tubes and hoses. Leaks can cause fires.

Inspect all lines, tubes and hoses carefully. Do not use your bare hands to check for leaks. Tighten all connections to the recommended torque.

Check for the following:

- End fittings damaged, leaking or displaced.
- Outer covering chafed or cut and wire reinforcing exposed.
- Outer covering ballooning locally.
- Evidence of kinking or crushing.

Make sure that all clamps, guards and heat shields are installed correctly to prevent vibration, rubbing against other parts, and excessive heat during operation.

## OILS

Hot oil and components can cause personal injury. Do not allow hot oil or components to contact the skin.

## **FIRE OR EXPLOSION PREVENTION**

All fuels, most lubricants, hydraulic oil, and some coolant mixtures are flammable. Diesel fuel is flammable. Gasoline is flammable. The mixture of diesel and gasoline fumes is extremely explosive.

Do not weld or flame cut on pipes or tubes that contain flammable fluids. Clean them thoroughly with nonflammable solvent before welding or flame cutting on them.

Clean and tighten all electrical connections. Check regularly for loose or frayed electrical wires. Refer to maintenance schedules for interval. Have all loose or frayed electrical wires tightened, repaired or replaced before operating the equipment.

Wiring must be kept in good condition, properly routed and firmly attached. Routinely inspect wiring for wear or deterioration. Loose, unattached, or unnecessary wiring must be eliminated. All wires and cables must be of the recommended gauge and fused if necessary. Do not use smaller gauge wire or bypass fuses. Tight connections, recommended wiring and cables properly cared for will help prevent arcing or sparking which could cause a fire.

## **FIRE EXTINGUISHER**

Have a fire extinguisher available and know how to use it. Inspect and have it serviced as recommended on its instruction plate.

## **CRUSHING OR CUTTING PREVENTION**

Support equipment and attachments properly when working beneath them.

Never attempt adjustments while the engine is running unless otherwise specified in this manual.

Stay clear of all rotating and moving parts. Guards should be in place whenever maintenance is not being performed.

Keep objects away from moving fan blades. They will throw or cut any object or tool that falls or is pushed into them.

Wear protective glasses when striking objects to avoid injury to your eyes.

Chips or other debris can fly off objects when struck. Make sure no one can be injured by flying debris before striking any object.

## **MOUNTING AND DISMOUNTING**

**Do not climb on, or jump off the equipment or stand on components which cannot support your weight. Use an adequate ladder. Always use steps and handholds when mounting and dismounting.**

**Clean steps, handholds and areas of the equipment you will be working on or around.**

## **BEFORE STARTING HAMMER**

**Make sure that all lifting equipment, including excavator, wire rope, slings, hooks, shackles, etc., are properly sized for the worst case loads anticipated during operations. Check wire rope clips for tightness, and check wire ropes for wear daily.**

**If there are any questions about the weights, specifications, or performance of the hammer, contact MKT before handling or operating the equipment.**

**Make sure that ground vibrations will not damage adjacent structures or excavations. Make sure no one is working on or close to the equipment before starting.**

## **HAMMER OPERATION**

**Only well trained and experienced personnel should attempt to operate or maintain this equipment.**

**Do not stand any closer to this equipment than necessary when it is in operation. Parts may loosen and fall. Piling may shatter or break.**

**Do not operate the hammer, excavator boom/arm, piles, wire rope and other equipment within 15' (5m) of electrical power lines, transformers and other electrical equipment, or within such distance as required by applicable safety codes.**

**Do not side-load excavator boom/arm or hammer. Dangerous excavator boom/arm or hammer damage may result.**

**III. SPECIFICATIONS**



**SPECIFICATIONS FOR THE V-8ESC VIBRATORY PILE DRIVER/EXTRACTOR SYSTEM**

**A. OPERATING DATA – V-8ESC DRIVER/EXTRACTOR**

Free Hanging Frequency.....	2250 CPM
Rated Drive Pressure.....	4500 PSI
Rated Flow.....	75 GPM
Free Hanging Amplitude.....	1/2 IN
Driving Force @ 2250 CPM.....	80 TONS
Clamp Circuit Pressure.....	2500 PSI
Clamping Force @2500 PSI.....	62 TONS
Maximum Pull Force with Bottom Clamp (16 Shear Blocks).....	32 TONS
Maximum Pull Force with Side Clamp Assembly.....	15 TONS
Standard Clamp Jaw Opening.....	1.25 IN
Clamp Cylinder Travel.....	2 IN
Side Clamp Jaw Opening.....	3 IN
Net Weight with Side Clamp and Rototilt.....	9250 LBS
Maximum Pile Weight.....	4000 LBS

\*NOTE: Frequency is set to maximize performance on a normal pile, and normal duty cycle. Should overheating occur to exciter due to high duty cycle, it is important that the unit be stopped and allowed to cool down. If overheating persists, reduce hammer cycles to 1700 - 1800 cpm and monitor temperature. If exciter temperature remains high (above 180 degrees Fahrenheit), contact your Factory Authorized Distributor for assistance.

#### IV. EXCAVATOR REQUIREMENTS

- A. The excavator size, stick width and pin dimensions must be compatible with the Rototilt width and pin dimensions.
- B. The excavator must be equipped with a uni-directional auxiliary circuit that can supply 75 GPM to the V-8Esc at 4,500 psi. The 75 GPM needs to be set using a flowmeter to 75 GPM with minimal restrictions in the system. The pressure needs to be set at 4,500 psi dead headed (zero flow). If you have any question on how to properly set flow or pressure please contact your local MKT representative or the factory.
- C. The auxiliary hydraulic circuit must supply at least 75 GPM and must flow oil in one direction only (uni-direction), it cannot have reverse flow, or damage to the V-8Esc hydraulic manifold may result. The circuit should be controlled by an electric on/off switch, not a bi-directional foot pedal.
- D. The excavator must have adequate lifting capacity to lift the combined weight of the hammer and pile at the required working radius.
- E.  **WARNING** The Rototilt RT80 has a maximum connecting pin size of 90mm and a maximum digging force of 44,960 lbs. If using an excavator with larger than 90mm pins or more than 44,960 lbs. of digging force you must reduce the pin size to 90mm and lower the digging force to 44,960 lbs. Consult your excavator supplier for the proper way to make these modifications.
- F.  **NOTICE** The V-8Esc electrical controls are operated using a 24v positively switched electrical supply. If your excavator system is negatively switched, you will need a relay in-line to operate the V-8Esc electrical controls. Please contact your local excavator dealer to determine what type of electrical system your specific excavator runs.

## V. SYSTEM SET-UP INSTRUCTIONS

### A. EXCAVATOR FLOW AND PRESSURE CHECK

Before connecting to the V-8Esc control manifold the auxiliary circuit of the excavator need to be activated to verify the hydraulic flow path. A flowmeter works best to determine this. The V-8Esc requires a flow of 75 GPM with no back pressure at a minimum of 4,500 psi.

**NOTICE** Reversing the auxiliary circuit or applying the flow to the manifold Return port will cause damage to the manifold's internal components.

### B. CONNECTION OF HOSES

All V-8Esc hammers are thoroughly tested at the factory and consequently all hoses will be filled with hydraulic fluid. If hoses are replaced or are otherwise unfilled with oil, take necessary steps to fill them before starting the hammer.

1. Three jumper hoses will need to be created in order to connect the excavator's axillary circuit supply, return and case drain to the corresponding ports on the V-8Esc control manifold. When jumper hoses are attached to the vibratory unit, extreme care should be made at all times not to kink any of the hoses.
  - a) **Drive Motor Hoses:** (2) each 1 ¼" hoses rated for safe operation at the excavator's maximum hydraulic pressure capability connected to hydraulic circuit ports (length of hoses to be determined by type of excavator). These hoses need -20 female JIC fittings on one end to plug into control manifold.
  - b) **Motor Drain Hose:** (1) each ¾" hose rated for safe operation at the excavator's maximum hydraulic pressure capability connected to the hydraulic circuit ports (length of hose to be determined by type of excavator). This hose needs a -12 female JIC fitting to plug into control manifold.



## 13 | SYSTEM SET UP INSTRUCTIONS

**NOTICE** For the case drain line minimal restriction back to the hydraulic reservoir is required.

**NOTICE** Failure to connect the drain line to the hydraulic reservoir will cause damage to the internal components of the manifold and cause V-8Esc drive motors to have seal failures.

**NOTICE** Whenever the hydraulic line of the V-8Esc system have been disconnected then reconnected for any reason the two side clamp cylinders and bottom clamp cylinder must be bled of entrained air. Please see the Bleeding the Clamps Section in the Start-Up Procedures of this manual for instructions on how to properly bleed the clamps.

**Any damaged hose within the vibratory hammer should be replaced with a hose of equivalent ratings.**

2. Before making any hydraulic hose connections, assure that the connectors are wiped clean of any dirt or contamination to prevent damage to the components in the hydraulic system.
3. Do not permit mobile equipment to run over any hydraulic hoses. The hydraulic hoses, even though filled with hydraulic oil, are not able to withstand external compression forces.
4. The ends of the jumper hoses should be carefully wiped clean and connected, according to size, to the V-8Esc control manifold.
5. Make it a habit whenever hydraulic lines are subsequently disconnected to immediately cap or plug them to avoid becoming dirty and introducing contamination, into and damage to, the components of the hydraulic system. Assure that the caps and plugs are wiped clean of any dirt or contamination before using.

### C. ELECTRICAL CONNECTIONS

Whether using custom joysticks designed specifically for an excavator or the standard MKT electrical stand, there will be one cord that goes down the boom from the excavator to the V-8ESC control manifold.

#### 1. POWER SUPPLY

The cable with the red shrink tube is for the 24v supply. White is positive, black is negative and needs to be connected to a 24v power supply.

#### 2. AUXILIARY CONTROL CIRCUIT

The cable with the blue shrink tube is to be used to control the auxiliary circuit on the excavator. Due to the wide range of excavator controls, please contact your local excavator dealer to determine what type of electrical system your specific excavator runs.

This requires a 24v signal; white is positive and black is negative.

**NOTICE** If the excavator electrical system is negatively switched, a relay is needed in-line for our auxiliary control to control the system. Please contact a local MKT representative or the factory for information needed to install an in-line relay.

#### 3. MANIFOLD CONNECTION

Whether using custom joysticks designed specifically for an excavator or the standard MKT electrical stand, there will be one cable that goes down the boom from the excavator to the V-8ESC control manifold. This is the Rototilt control cable or Boom Cable and has a 10 pin connector on it. Run this cable down the boom and connect it to the corresponding 10 pin connector located on the manifold mount plate.

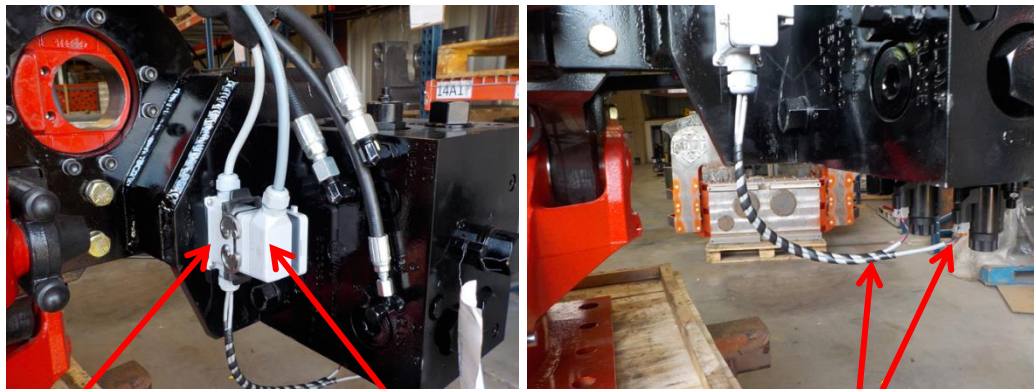

10 pin connector located on the manifold mount plate

Rototilt control cable that is run down the boom from the ESC Electrical Control Box

Solenoids #11/12 and #13 will come prewired.

## 15 | SYSTEM SET UP INSTRUCTIONS

### D. V-5ESC DRIVER/EXTRACTOR

The V-8ESC hammer is factory fitted with a suspension assembly and is shipped laying down in a specially designed shipping stand. It is designed to be pinned to the second member of an excavator via the RT-80 Rototilt mounted on top of the suspension. The V-5ESC hammer can be lifted from the horizontal to the vertical without danger of excessive stresses upon its connecting parts or structure.

### E. V-5ESC JAW SHIELDS

The Jaw Shields are generally shipped connected to the V-8ESC Clamp Assembly. Before using the V-8ESC, assure that the Jaw Shields are tightly connected (each with four hex head cap screws and lock washers) to the V-8ESC Clamp Assembly. The Jaw Shields not only act as guides for positioning the V-8ESC on a standing pile, but are also necessary to protect the jaws and the clamp assembly from unnatural impact shock and resulting damage.

## VI. START-UP PROCEDURES

### A. **DANGER** CLEAR THE AREA

Verify all personnel are clear of the vibratory hammer before proceeding.

### B. POWERING UP THE CONTROLS

1. With the excavator running turn the power switch on the junction box to the ON position
2. Once the ESC Electrical Control box has been powered up, press the green power button in the bottom left corner of the wireless remote. Both the transmitter and the receiver will time out / turn off after 30 minutes of inactivity.



Note: The power to the junction box has to be turned on before the remote can be turned on. If the remote is turned on first the system will not recognize the remote.

## 17 | START UP PROCEDURES

### C. OPERATION OF THE UNIT

Once the proper power up procedures have been completed the unit is ready to be controlled.

1. TILT and ROTATE functions are controlled by pressing the corresponding tilt left / tilt right and rotate left / rotate right buttons.



1. CLAMP function is controlled by first holding the clamp PTO (push to operate) button. Once the PTO is held the clamp can now operate by pushing either the clamp open or clamp close buttons.



**⚠ DANGER** Verify again that all personnel are clear before vibrating the clamps. The side clamp cylinders and bottom clamp are on a common hydraulic circuit so all three cylinders will actuate at the same time.

- VIBRATORY function is controlled by first holding the vibro PTO (push to operate) button. While you have the PTO held down press vibro start to start the vibratory hammer. The V-5ESC will continue to vibrate without holding the buttons. To stop the vibratory hammer press the vibro stop button.

NOTE: While turning the V-5ESC off the PTO does not need to be pushed.

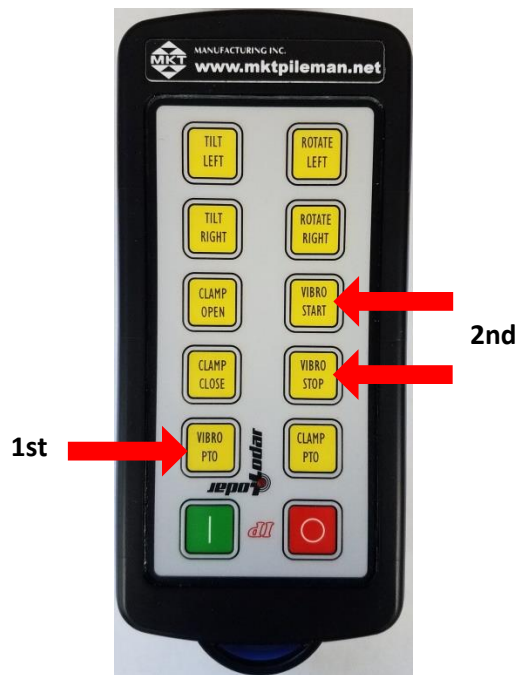

**⚠ DANGER** Verify again that all personnel are clear before vibrating the V-5ESC.

#### D. BLEEDING THE CLAMP CIRCUIT

**NOTICE** Whenever the hydraulic line of the V-5ESC system have been disconnected then reconnected for any reason the two side clamp cylinders and bottom clamp cylinder must be bled of entrained air. In order to effectively bleed all entrained air from the system the hammer must be in the vertical, upright position.

**⚠ WARNING** Contents of hydraulic components may be under pressure and extreme care should be taken when opening or bleeding components.

## 19 | START UP PROCEDURES

### 1. BOTTOM CLAMP

Follow the instructions found in the start-up portion of this manual to operate the clamp functions. Close the jaws and hold the clamp close function while you open the bleeder on the back of the bottom clamp.

**⚠ WARNING** Do not back vent screw all the way out!

Allow oil to vent approximately 30 seconds or until an air free stream of oil comes from each vent screw.

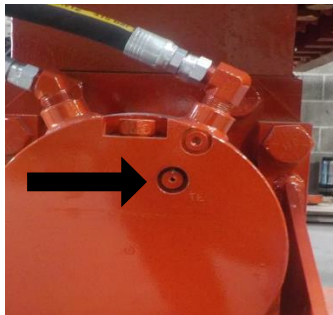

### 2. SIDE CLAMP CYLINDERS

Follow the instructions found in the start-up portion of this manual to operate the clamp functions. Close the jaws and hold the clamp close function while you open the bleeder on the back of the bottom clamp first. Once the bottom clamp cylinder has been bled repeat the steps and bleed the top cylinder.

**⚠ WARNING** Do not back vent cap all the way out!

Allow oil to vent approximately 30 seconds or until an air free stream of oil comes from each vent screw.

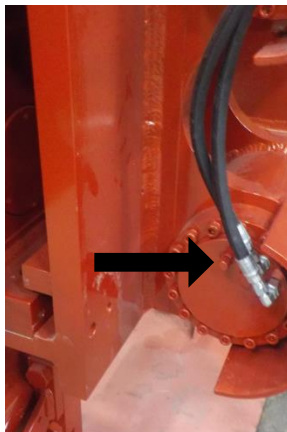

**BOTTOM 1st**



**TOP 2nd**

## E. BLEEDING THE CLAMP CIRCUIT

The V-8Esc comes factory set at an optimum frequency of approximately 2,250 cycles per minute. If for any reason the frequency needs to be recalibrated the following procedure needs to be followed in order to reset the proper cycles. A photo-tachometer will be required in order to complete the following steps.

1. The number of cycles the V-8Esc is currently operating at needs to be determined. To do this hold the laser or light beam from a photo-tachometer on the bottom edge of the exciter case while the vibratory hammer is vibrating. The number that the photo-tach generates is the frequency of the vibratory hammer or the amount of times the four eccentrics in the V-8Esc complete a full revolution per minute.
2. **⚠ WARNING** To make adjustments safely the flow control cartridge, labeled #8 on the V-8Esc control manifold, will need to be adjusted with the V-8Esc NOT VIBRATING.
  - a) In order to reduce the cpm or slow the hammer down, turn the set screw in.
  - b) In order to increase the cpm of speed the hammer up, turn the set screw out.
  - c) When the necessary adjustments have been made, start the V-8Esc and check the cycles again using the procedure outline in section 1 of setting the cycles portion of this manual.
  - d) Repeat the above steps until a frequency of between 2,200 – 2,250 cpm has been reached.

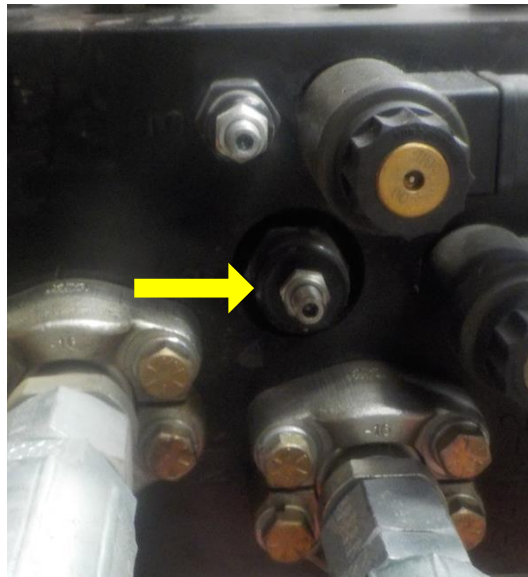



## VII. OPERATING INSTRUCTIONS

### DRIVING MODE

#### A. OPERATING THE V-8Esc SYSTEM - DRIVING MODE

1. First, check that the lifting capacity of the excavator, at the working radius, exceeds the combined weight of the V-8Esc assembly and the pile. Then, lift the pile using an appropriately sized cable between the lifting point on the Rototilt assembly and the lifting hole in the pile. (Refer to figures 1 and 2). Once the pile is hanging nearly vertical, guide it into the hammer jaws or thread the pile into an already driven pile. Position the jaws on the pile (see figure 2) and close the jaws and start the hammer. The vibration, coupled with the down crowd force of the excavator drives the pile. Do not exceed the down crowd force rating.

**⚠ DANGER** Always use the pile handling/ safety cable to attach the pile to the hammer.

2. Cut pile handling holes 2ft. or more above center of the pile on either side of center as required to position pile in jaws as shown in figure 1.

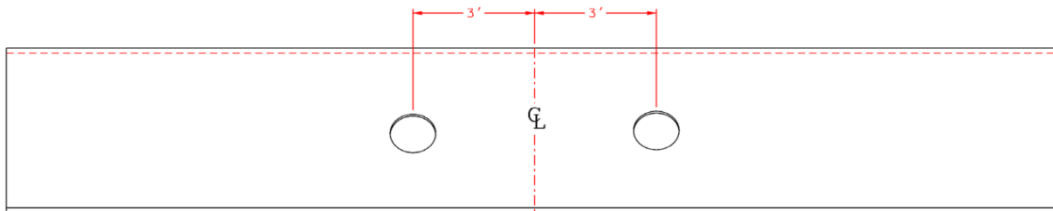

FIGURE 1

3. The worksite needs to be level to maximize the speed of handling and driving the pile.
4. As soon as headroom allows, move the pile to the bottom clamp to maximize driving speed.
5. The side clamp jaws are intended to be used to start and drive the pile in soft driving conditions. For best results and longer hammer life, the bottom clamp should be used whenever possible. When using the side clamps, line pull should be limited to 15 tons and crowd force limited to 15 tons. If the side clamp jaws slip on the pile stop the hammer and move to the bottom clamp.
6. **NOTICE** Do not start hammer with jaws open. The V-8Esc will vibrate with the jaws open or closed.

## 21 | OPERATING INSTRUCTIONS

7. **⚠ WARNING** Always maintain proper vertical alignment between the suspension and pile when driving or pulling the pile.
8. Occasionally the inability of the V-8Esc hammer to continue to move a pile will be the result of the pile striking an impenetrable soil material or an obstruction. The observable action of the V-8Esc hammer and clamped pile will be to note a considerable fall-off of drive pressure and the exciter will “dance” in place often causing erratic interaction of the V-8Esc exciter and its suspension assembly. If the V-8Esc is mounted to an excavator or backhoe do not apply more crowd force than the maximum recommended.

**⚠ CAUTION** Whenever the V-8Esc hammer is observed “dancing or chattering” in place, it should be hoisted until the action stops. Failure to move a pile with the hammer “dancing or chattering” should be cause to promptly abandon the effort before serious damage is done to the hammer. To continue operations the obstruction must be removed or penetrated by switching to another driving system such as a larger vibro or a MKT diesel or air pile hammer.

**⚠ DANGER** For each lift, the operator must review the excavator lifting capacity to determine that the weight of the V-8Esc/Rototilt assembly plus the load being lifted is within the rated capacity of the excavator

**⚠ DANGER** Keep hands clear of all three clamps at all times.

**⚠ DANGER** Leave the pile safety cable attached to the pile at all times that the pile is not stuck securely in the ground.

**⚠ DANGER** The V-8Esc side clamp attachment is designed to handle a single pile with a **MAXIMUM** weight of 2 TONS. Appropriate pile lifting rigging should be supplied by the end user to handle the pile in a safe manner. Attach cable(s) to lifting eye(s) on the hammer to allow safe handling of the pile and placing it in the jaws as shown in figure 2.

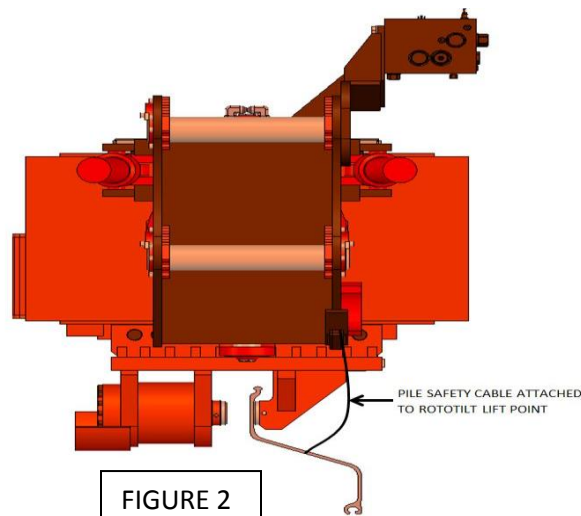

## EXTRACTING MODE

### B. OPERATING THE V-8Esc SYSTEM – EXTRACTING MODE

1. For pile extracting operations, a pile safety cable is to be used in the same manner outlined in the driving mode portion on this manual. Once the V-8Esc hammer is clamped to the steel sheet pile to be pulled and the safety cable is fastened into a lifting hole in the pile, the pile is ready to be extracted. The V-8Esc hammer is operated to extract the pile until the pile can be easily lifted out of place exclusively by the extraction force of the excavator. The V-8Esc hammer is then stopped by pushing VIBRO off on the radio remote control. The pile is pulled out of the ground and the hammer and pile are swung to where the pile will be stacked. The lower end of the pile is set on the ground and the V-8Esc hammer jaws are opened allowing the pile to hang by the pile safety cable. The V-8Esc hammer and pile are then lowered to the ground where the line is disconnected from the pile.
2. The side clamp jaws are intended to be used to pull the pile in soft extracting conditions. For best results and longer hammer life, the bottom clamp should be used whenever possible. When using the side clamps line pull should be limited to 15 tons and crowd force limited to 15 tons. If the side clamp jaws slip on the pile stop the hammer and move to the bottom clamp.

 **DANGER** Do not unclamp the jaws from the pile while the hammer is vibrating.

3. The amount of pull which can be exerted on the V-8Esc hammer is limited by the rating of the suspension assembly and the strength of the pile.

 **DANGER** Do not pull in excess of the rating of the V-8Esc hammer suspension assembly or excess stressed will be put on the suspension assembly damaging one or more parts.

 **WARNING** Always maintain proper vertical alignment between the suspension and the pile when driving or pulling the pile.

## 23 | OPERATING INSTRUCTIONS

**⚠ WARNING** The hammer and suspension must be kept in alignment with each other, and with the pile, when driving or extracting. Failing to do so will result in damage to the jaws and clamp cylinders.

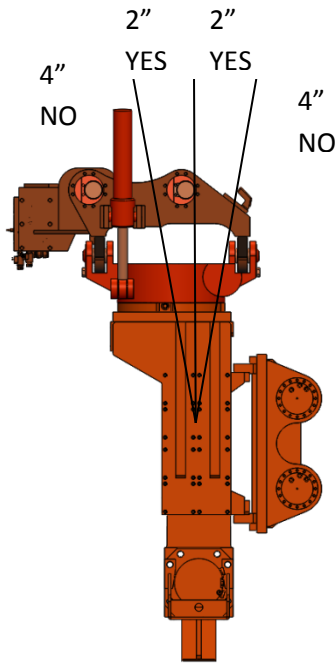

Hammer, suspension and pile inline

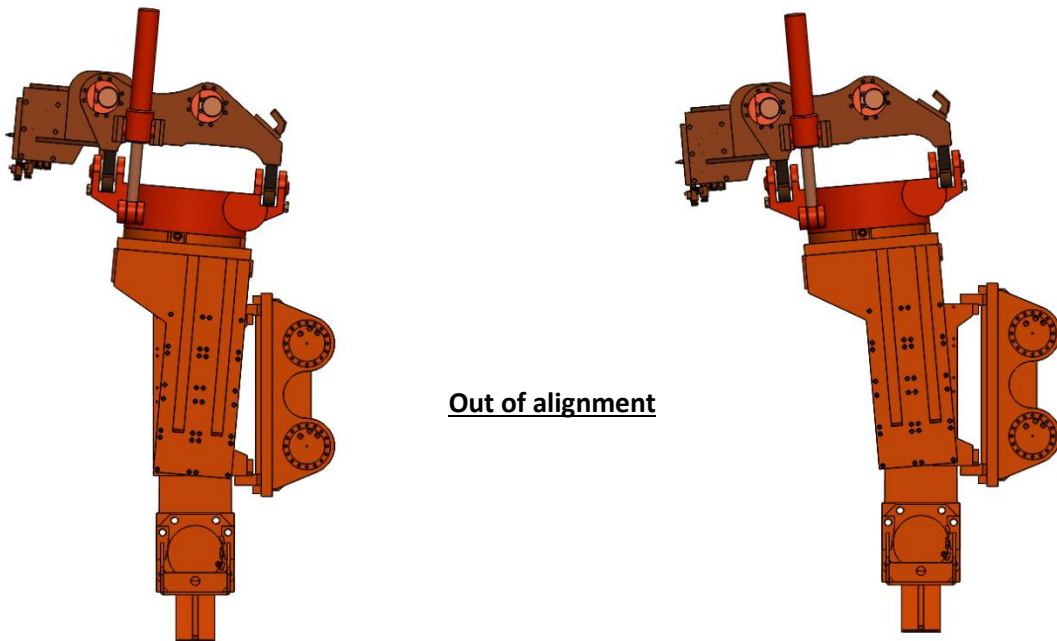

**If the jaws slip on the pile STOP DRIVING AND IDENTIFY THE PROBLEM**

## VIII. MAINTENANCE AND SERVICE INSTRUCTIONS

- A. The V-8Esc hammer should be inspected regularly to help keep it in good operating condition. The time interval between necessary adjustments and repairs depends primarily on how much and how hard the machine has been used. Repair or replace broken or damaged parts as soon as they are discovered. Periodic cleaning and repainting will help keep all parts in better working order and prolong the machine's life.
- B. Properly maintaining the total V-8Esc system begins with cleanliness; assuring that no dirt or foreign material enters the hydraulic fluid circuit. Contamination of the components of the hydraulic system pumps, motors, valves, etc., will result in erratic operation, down-time, shortened equipment life, damaged parts and expensive repair or replacement parts costs.
- C. The hydraulic fluid level in the system should be maintained at all times. Leaks in the hydraulic system, particularly noticeable after transport and re-set-up of this system, should be eliminated by checking, tightening or replacing leaking parts. Hose connections may leak as a result of manipulating and straightening the lines and should be promptly tightened. **THE CAUSE OF HYDRAULIC LEAKS WHICH CANNOT BE CORRECTED SHOULD BE ELIMINATED BY CALLING FOR FACTORY AUTHORIZED DISTRIBUTOR SERVICE ASSISTANCE.**
1. In normal, safe operation of the V-8Esc system, the hydraulic fluid temperature should remain in its normal range of 115 degrees Fahrenheit to 165 degrees Fahrenheit. The temperature can be read on the thermometer which is integral to the reservoir fluid level gauge. **IF THE HYDRAULIC OIL TEMPERATURE BECOMES EXCESSIVE (ABOVE 180 DEGREES FAHRENHEIT), STOP OPERATIONS AND CONSULT WITH THE NEAREST FACTORY AUTHORIZED SERVICING DISTRIBUTOR.**
- D. Daily check all hoses for cuts or other damage. Hoses are sometimes cut or bruised by dragging them across the pile heads while setting the V-8Esc hammer. Stop V-8Esc hammer operations that may damage hoses and redirect hoses to avoid dragging and damage. Damaged hose sections must be replaced to eliminate failure and down-time during operations.
- E. Inspect the V-8Esc hammer for normal hanging posture and tightened fasteners, particularly on the suspension and clamp assemblies before and during operation.

 **WARNING** STAND AWAY FROM THE PILE AND FROM BELOW THE V-8Esc HAMMER DURING VIBRATING OPERATIONS. ANY UNOBSERVED, UNCORRECTED, LOOSE NUT OR OTHER FASTENER MAY FALL.

## 25 | MAINTENANCE AND SERVICE INSTRUCTIONS

- F. Assure that the proper lube oil level is maintained in the V-8Esc exciter case. If the level of oil is above the sight gauge or the lube oil volume is increasing, this will indicate that the hydraulic motor is leaking hydraulic fluid through the motor drive shaft seal. The seal leakage must be corrected immediately. Exciter lube oil must be changed if seal failure occurs.
- G. The V-8Esc system normally the hammer lines and components filled with hydraulic fluid. Whenever the system has been completely or partially drained (as when a new hose section is replaced), the hydraulic lines must be purged of air. To purge the clamp lines, bleed the bottom and side clamp cylinders using the process outlined above in the system start-up portion of this manual
- H. Daily Maintenance Check Lists - Check the entire unit prior to and during start-up each shift.
  - 1. Prior to starting the V-8Esc at each shift, check as follows:
    - a) Visually check all hoses for signs of damage or cuts that might cause hose failure during operation. Be sure all connections are tight, especially the quick disconnects.
    - b) Look for any damage to the unit, in general that might cause it to fail when put into operation.
    - c) Check the V-8Esc exciter case lube oil level. With exciter cold, lube level should be just below the top of the sight glass.
    - d) Check the V-8Esc clamping jaws for excessive wear, cracks or loose fasteners. If it is necessary, the removal of the movable jaw is done by pushing out the 3/4" roll pin either up or down. The single vertical roll pin captivates the movable jaw. The fixed jaw is held tight against the housing with two one-inch bolts. Also, operating the V-8Esc on piling without the Jaw Shields could result in jaw damage if the hammer is dropped onto the pile.

2. After start up and the V-8Esc is vibrating, check as follows:

a) Inspect the hydraulic lines for leaks.

b) **NOTICE** Allow hydraulic oil temperature to come up slightly above the oil pour temperature, preferable to 50 degrees Fahrenheit before starting the hammer.

c) Before attaching to pile, open and close clamp jaws to verify fast and positive action.

d) Be sure that there are no kinks in the lines and that they hang uniformly.

e) Always maintain a close check on the pile safety cable to assure no fraying has occurred.

f) Check for overheated bearing housings. Please refer below to item 2, Exciter Overheating In Specific Local Areas, in the Service Trouble Shooting portion of this manual for more information what to look for when checking for overheated bearing housings.

I. The V-8Esc exciter case has been filled with the proper fluid at the factory. Use the following list for adding fluids which are compatible with those used at the factory:

1. **V-8Esc ExciterLube Oil**

Shell Omala RL 220 Synthetic ..... Capacity – 4 Gallons

a) Change after every 50 hours of driving time, sooner if contaminated or discolored.

**MKT V-8ESC DAILY CHECKLIST**

**OK      NEEDS  
          MAINTENANCE**

- 1.             Check the hours on the hour meter for the vibratory hammer. Intervals are every 50 hours or as needed.
  
- 2.             Check the lube oil level on site glass with exciter hanging level. Oil level should be at half to three quarters in the glass.
  
- 3.             Inspect rubber elastomers for signs of damage.
  
- 4.             Inspect all hydraulic hoses and connections for signs of wear or damage (broken wires, kinks, leaks, etc.).
  
- 5.             Check that all fasteners (nuts & bolts) are tight.
  
- 6.             Inspect all jaws for signs of wear.
  
- 7.             Inspect the chrome surface on the side clamp cylinder for damage.
  
- 8.             Check the grease Zerks on the hammer and Rototilt to insure these items are being greased properly. See manual for procedure.

Prior to the use of this equipment everyone that will be or will assist in operating this equipment must read and understand the MKT V-8Esc Operating, Maintenance and Service Manual. Failure to read and understand the MKT V-8Esc Operating, Maintenance and Service Manual may result in property damage, severe injury or death.

PLEASE PRINT: \_\_\_\_\_

SIGNATURE: \_\_\_\_\_

DATE: \_\_\_\_\_

## IX. SERVICE TROUBLE SHOOTING

### A. V-8Esc VIBRATORY HAMMER

#### 1. Increase In Exciter Lube Oil Level

This is a sure sign that the hydraulic motor has a shaft seal failure. If submerged under water, water may have seeped into the exciter case.

#### 2. Exciter Overheating In Specific Local Areas

Checking the side covers for the bearings will give an indication of an overheating bearing. This bearing should be checked for excessive binding or wear. Make sure the oil level is correct. It is not unusual for the temperature of the exciter housing to go up to 200 degrees Fahrenheit if the V-8Esc is run at full frequency over a long period of time. Check the lower magnetic plug for metal which might indicate excessive wear of gears or bearings.

#### 3. Internal Noise In Exciter

Unusual noise in exciter generally means something is wrong - either a bearing is starting to fail, gear train restriction, or a hydraulic motor problem causing excessive drive loading. Lube oil level should be checked.

#### 4. V-8Esc Frequency Fluctuation

Frequency is a function of pump flow and motor speed. If the pump flow is not even or a hydraulic motor is failing, it is possible the frequency will not be constant especially as the load goes a little higher (before going over relief). Check for exciter hotspots which may indicate a bearing is failing.

#### 5. Erratic Suspension Movement

High blow count soil conditions or underground obstructions may cause the hammer energy to rebound into the suspension and affect the suspension isolation. The suspension will bounce out of sync with the frequency, which will eventually cause the elastomers to overheat and fail.

#### 6. Slow Clamp Movement

Generally, slow clamping is caused by air in the hydraulic hoses. Bleed both clamp close and clamp open bleeders of the bottom and side clamp cylinders using the process outlined above in the system start-up portion of this manual.

## 29 | SERVICE TROUBLE SHOOTING

### 7. Jaws Slipping on Pile

- a) If jaws are worn too much there may be a lack of clamping jaw travel. The clamp jaw travel is two and one half inches.
- b) Check clamping pressure.
- c) Air may be in the clamp line requiring cylinder bleeding using the process outlined above in the system start-up portion of this manual.

### 8. No Vibration But Drive Pressure at 4500 PSI When Put In Vibrate Mode

Assuming the drive hoses are not blocked and are connected fully and correctly, there may be a locked bearing, gear, or motor.

### 9. V-8Esc Not Coming Up To Speed And/Or Pressure Very Low

Relief valve in the directional control valve may be clogged. The system may have a worn out motor.

### 10. V-8Esc Frequency Low But Pressure High

The motor seal might have blown filling the V-8Esc Exciter Case with oil. Check the lube oil level. The exciter case may have a bearing failure. Check for excessive exciter case heat.

This information is included for the user to have a point of reference while discussing trouble shooting actions with his factory authorized distributor's service department. Call your nearest MKT factory authorized distributor's service department to remedy any abnormal occurrences in the operation of your V-8Esc system.

Successful internal repairs and general overhaul of a V-8Esc hydraulic vibratory pile driver/extractor system must be handled as a clean shop procedure. MKT factory authorized distributors are properly equipped and should be contacted to provide such service.

For the name and address of the nearest MKT factory authorized distributor call MKT **Manufacturing Inc., St. Louis, Missouri at 314/388-2254**

## **X. DRAWING AND PARTS LISTS**

This manual includes the following Drawings and Parts Lists:

- A. V-8Esc GENERAL ASSEMBLY AND PARTS LIST**
- B. EXCITER CASE ASSEMBLY**
- C. ECCENTRIC SHAFT ASSEMBLY AND PARTS LIST**
- D. MOTOR SHAFT ASSEMBLY AND PARTS LIST**
- E. V-8Esc HYDRAULIC CLAMP ASSEMBLY AND PARTS LIST**
- F. SIDE CLAMP ASSEMBLY**
- G. ROTOTILT ASSEMBLY**
- H. MANIFOLD ASSEMBLY**
- I. V-8Esc HYDRAULIC SCHEMATIC AND PARTS LIST**
- J. ELECTRICAL SCHEMATIC**
- K. SAFETY DECAL KIT LOCATIONS**

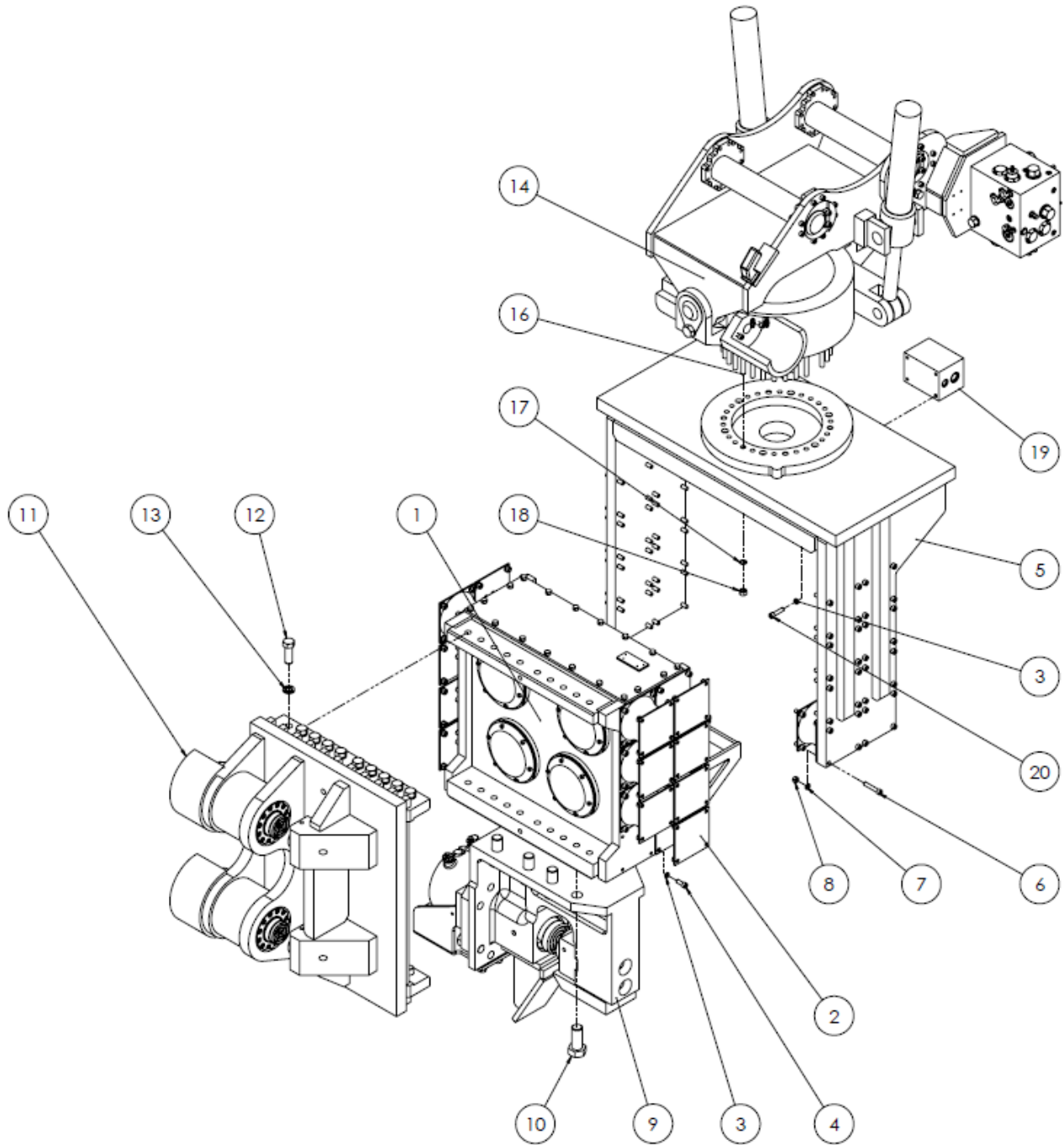

**V-8ESC GENERAL ASSEMBLY**

**V-8ESC GENERAL ASSEMBLY**

<b>ITEM NO.</b>	<b>MKT PART NUMBER</b>	<b>DESCRIPTION</b>	<b>QTY.</b>
1	Exciter Assembly	V-8ESC EXCITER CASE ASSEMBLY	1
2	9410024	ELASTOMER SHEAR BLOCK	16
3	9030413	HIGH COLLAR LOCK WASHER 1/2"	68
4	9050711	SOCKET HEAD CAP SCREW 1/2-13 x 1-1/4"	64
5	4080010	SUSPENSION HOUSING	1
6	9050723	SOCKET HEAD CAP SCREW 1/2-13 x 2-3/4"	64
7	9030608	LOCK WASHER 1/2"	64
8	9000015	HEX NUT 1/2-13	64
9	4080016	V-8ESC CLAMP ASSEMBLY ROUND JAWS	1
10	9016313	HEX HEAD CAP SCREW 1-1/2-6 x 3-1/2"	8
11	4080033	SIDE CLAMP ASSEMBLY	1
12	9016117	HEX HEAD CAP SCREW 1-8 x 3"	20
13	4080035	ROTOTILT ASSEMBLY	1
14	9030608	LOCK WASHER 1/2"	18
15	9500009	FLAT WASHER M16	28
16	9500143	SOCKET HEAD CAP SCREW M12x1.75 x 300MM	28
17	9500310	DISC LOCK WASHER	28
18	9500215	HEX NUT M12x1.75	28
19	4080057	MOTOR SUPPLY & RETURN MANIFOLD	1
20	9050171	SOCKET HEAD CAP SCREW 1/2-13 x 2"	4

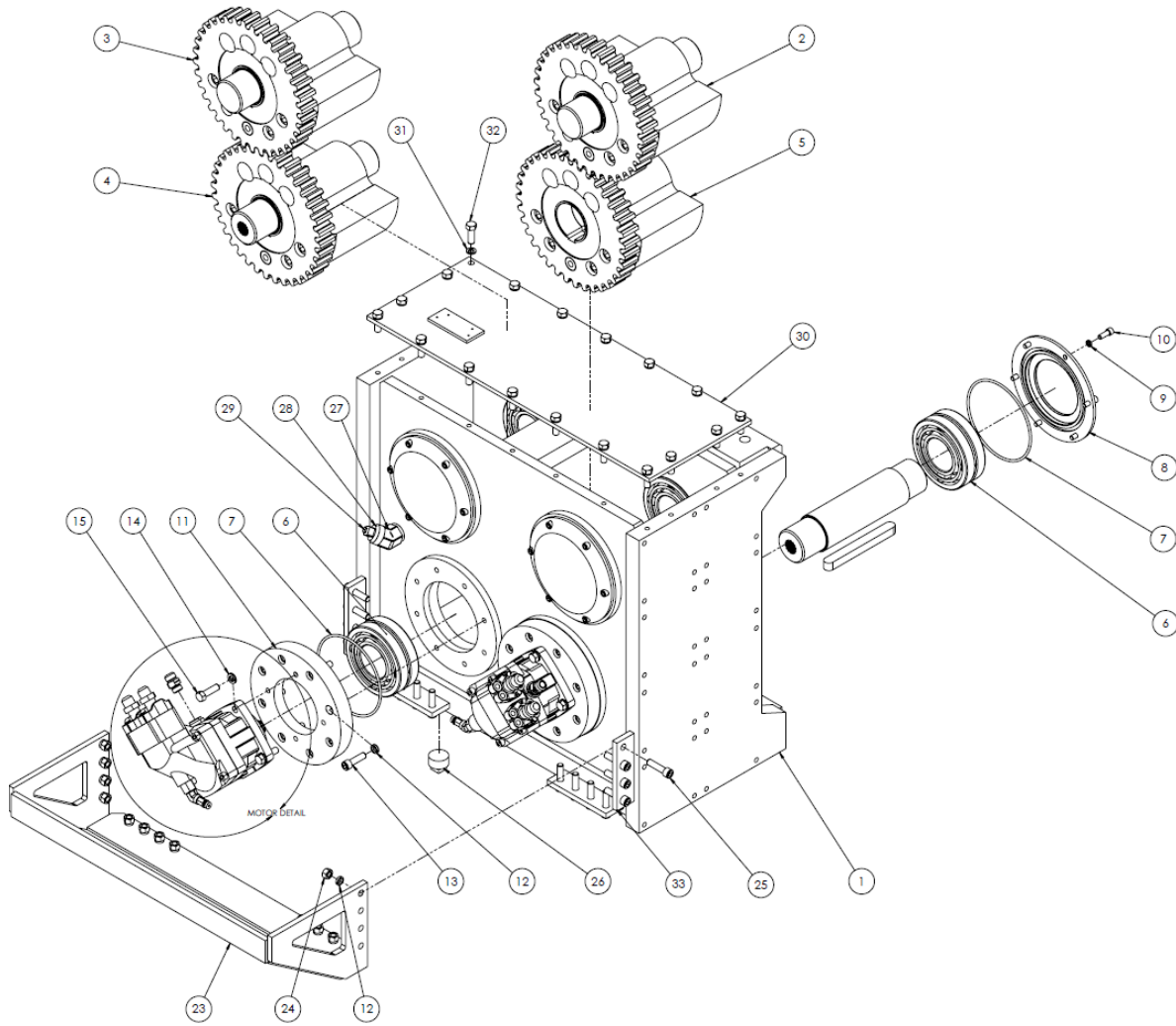

**V-8ESC EXCITER CASE ASSEMBLY**

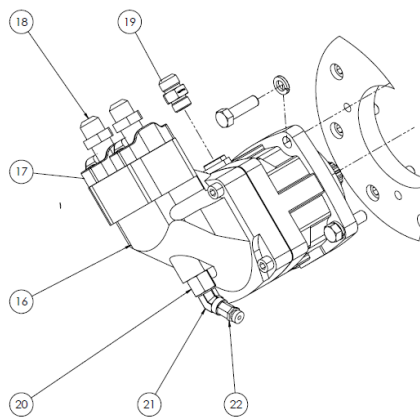

MOTOR DETAIL

**HYDRAULIC MOTOR DETAIL**

## V-8ESC EXCITER CASE ASSEMBLY

ITEM NO.	MKT PART NUMBER	DESCRIPTION	QTY.
1	4080002	EXCITER MACHINING	1
2	4080030	ECCENTRIC SHAFT ASSEMBLY	1
3	4080031	ECCENTRIC SHAFT ASSEMBLY	1
4	4080032	DRIVE ECCENTRIC SHAFT ASSEMBLY	1
5	4080061	DRIVE ECCENTRIC SHAFT ASSEMBLY	1
6	9140130	SPHERICAL ROLLER BEARING	8
7	9130230	O-RING	8
8	4080022	BEARING COVER	6
9	9030411	HIGH COLLAR LOCK WASHER 3/8"	36
10	9050511	SOCKET HEAD CAP SCREW 3/8-16 x 1"	36
11	4080027	MOTOR BEARING COVER	2
12	9030413	HIGH COLLAR LOCK WASHER 1/2"	32
13	9050713	SOCKET HEAD CAP SCREW 1/2-13 x 1-1/2"	16
14	9030608	LOCK WASHER 1/2"	8
15	9015715	HEX HEAD CAP SCREW 1/2-13 x 1-3/4"	8
16	9100079	HYDRAULIC MOTOR	2
17	9230991	SPLIT FLANGE ADAPTER KIT	4
18	9231424	HYDRAULIC ADAPTER 6842-12-12	4
19	9230588	HYDRAULIC ADAPTER 6400-8-10	2
20	9231208	HYDRAULIC ADAPTER 6405-10-4	2
21	9231412	HYDRAULIC ADAPTER 5503-4-4	2
22	4050283	DRAIN RELIEF	2
23	4080059	MOTOR GUARD	1
24	9000015	HEX NUT 1/2-13	16
25	9050717	SOCKET HEAD CAP SCREW 1/2-13 x 2"	16
26	9310002	MAGNETIC PLUG	2
27	9300573	1" PIPE ELBOW	1
28	4020207	FILL PLUG	1
29	9420011	RELIEF FITTING	1
30	4080034	EXCITER COVER	1
31	9030607	LOCK WASHER 7/16"	18
32	9015613	HEX HEAD CAP SCREW 7/16-14 x 1-1/4"	18
33	4080059-1	MOTOR GUARD MOUNT	4
34	9310479	SIGHT GLASS	1

**35 | DRAWING AND PARTS LISTS**

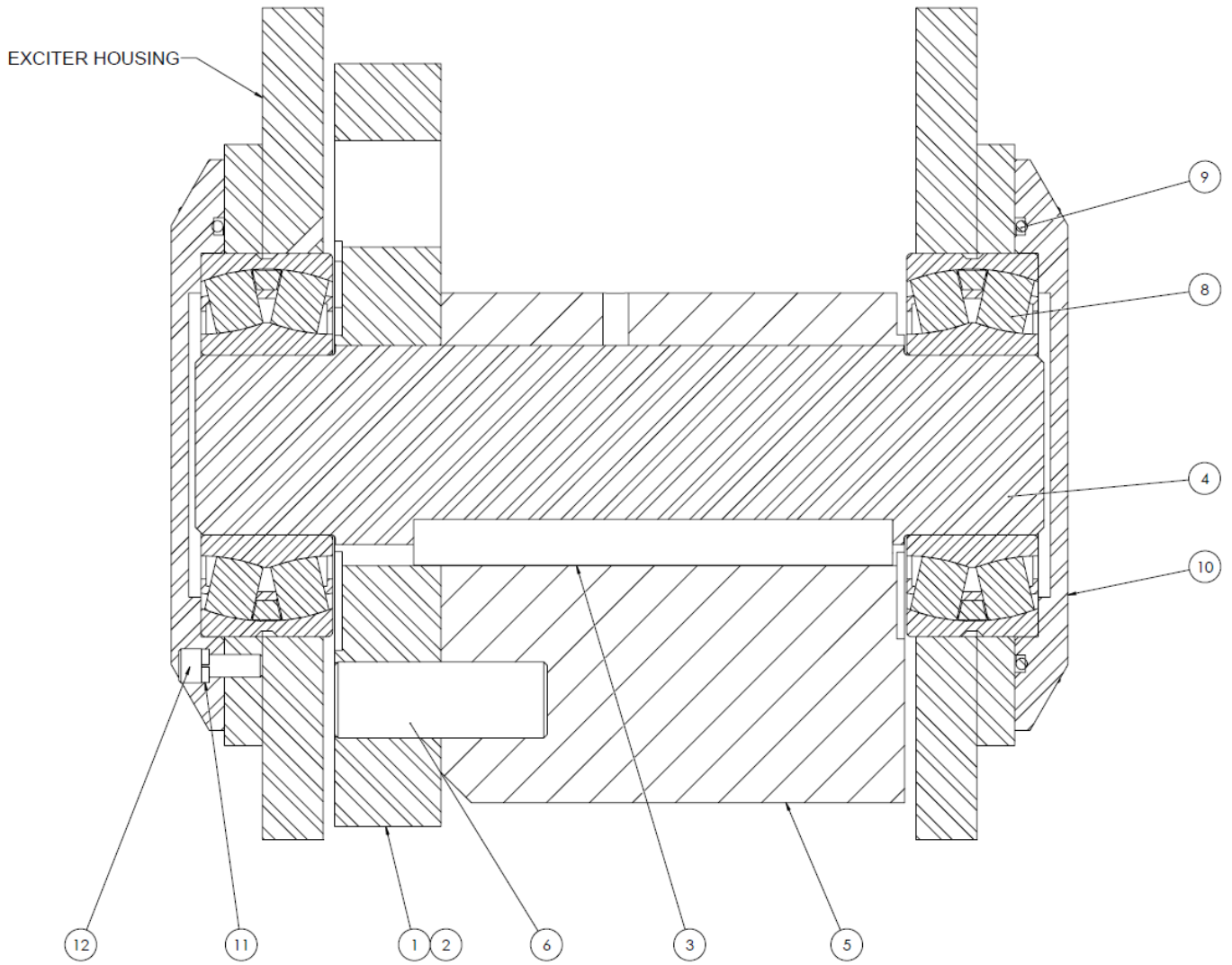

**V-8ESC ECCENTRIC SHAFT ASSEMBLY (420 10 05/06)**

**V-8ESC ECCENTRIC SHAFT ASSEMBLY (408 00 30/31)**

<b>ITEM NO.</b>	<b>MKT PART NUMBER</b>	<b>DESCRIPTION</b>	<b>QTY.</b>
1	4080018	ECCENTRIC GEAR	1
2	4080019	ECCENTRIC GEAR	1
3	4080025	ECCENTRIC KEY	1
4	4080020	ECCENTRIC SHAFT	1
5	4080026	ECCENTRIC	1
6	4300043	PIN	1
7	9050915	SOCKET HEAD CAP SCREW 3/4-10 x 1-3/4"	4
8	9140130	SPHERICAL ROLLER BEARING	2
9	9130230	O-RING	2
10	4080022	BEARING COVER	2
11	9030411	HIGH COLLAR LOCK WASHER 3/8"	6
12	9050511	SOCKET HEAD CAP SCREW 3/8-16 x 1"	6

**37 | DRAWING AND PARTS LISTS**

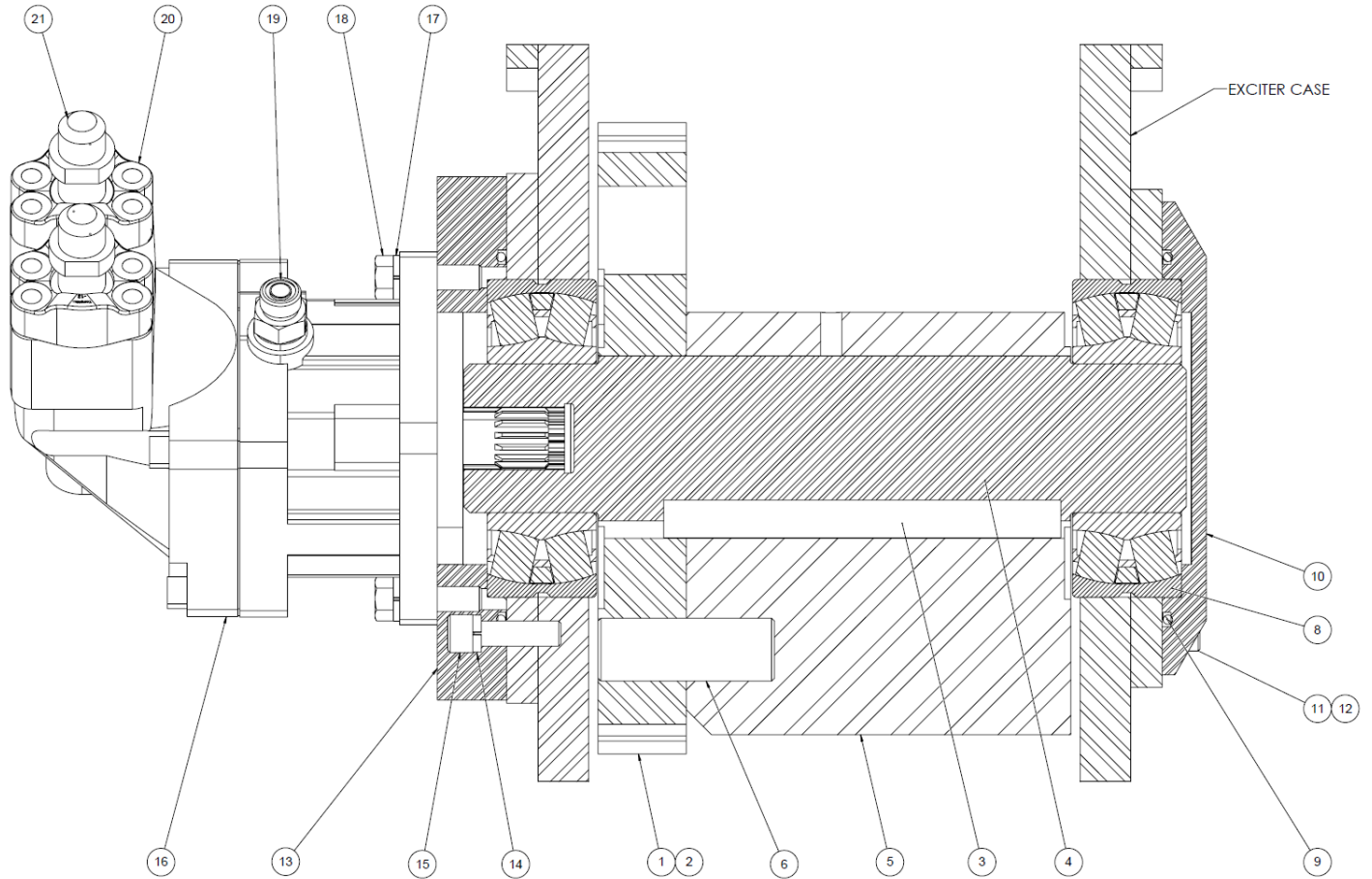

**V-8ESC DRIVE SHAFT ECCENTRIC ASSEMBLY (408 00 32/61)**

**V-8ESC MOTOR SHAFT ASSEMBLY (408 00 32/61)**

<b>ITEM NO.</b>	<b>MKT PART NUMBER</b>	<b>DESCRIPTION</b>	<b>QTY.</b>
1	4080018	ECCENTRIC GEAR	1
2	4080019	ECCENTRIC GEAR	1
3	4080025	ECCENTRIC KEY	1
4	4080028	DRIVE SHAFT	1
5	4080026	ECCENTRIC	1
6	4300043	PIN	1
7	9050915	SOCKET HEAD CAP SCREW 3/4-10 x 1-3/4"	4
8	9140130	SPHERICAL ROLLER	2
9	9130230	O-RING	2
10	4080022	BEARING COVER	1
11	9030411	HIGH COLLAR LOCK WASHER 3/8"	6
12	9050511	SOCKET HEAD CAP SCREW 3/8-16 x 1"	6
13	4080027	MOTOR BEARING COVER	1
14	9030413	HIGH COLLAR LOCK WASHER 1/2"	8
15	9050713	SOCKET HEAD CAP SCREW 1/2-13 x 1-3/4"	8
16	9100079	HYDRAULIC MOTOR	1
17	9030608	LOCK WASHER 1/2"	4
18	9015715	HEX HEAD CAP SCREW 1/2-13 x 1-3/4"	4
19	9230588	HYDRAULIC ADAPTER 6400-8-10	1
20	9230991	SPLIT FLANGE ADAPTER KIT	2
21	9231424	HYDRAULIC ADAPTER NB6842-12-12	2

# 39 | DRAWING AND PARTS LISTS

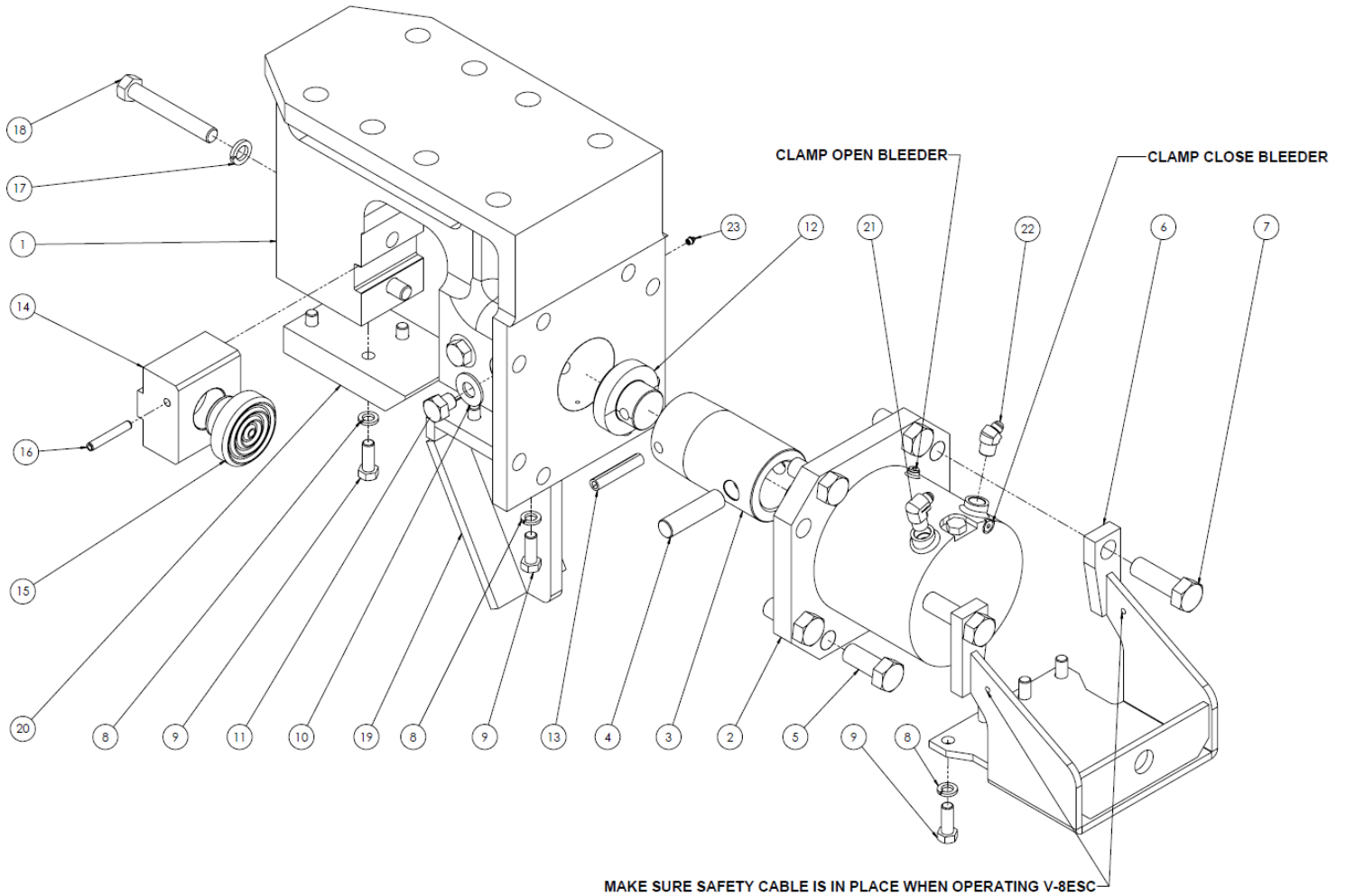

## **BOTTOM CLAMP ROUND JAWS (408 00 16)**

**BOTTOM CLAMP ROUND JAWS (408 00 16)**

ITEM NO.	MKT PART NUMBER	DESCRIPTION	QTY.
1	4080029	CLAMP HOUSING	1
2	4160131	HYDRAULIC CYLINDER	1
3	4950063	CLAMP SLIDE	1
4	4200138	PIN, CLAMP SLIDE	1
5	9016218	HEX HEAD CAP SCREW 1 1/4-12 x 3"	6
6	4050358	CYLINDER GUARD	1
7	9016224	HEX HEAD CAP SCREW 1 1/4-12 x 4"	2
8	9030610	LOCKWASHER 3/4"	12
9	9015917	HEX HEAD CAP SCREW 3/4-10 x 2"	12
10	9020107	FLAT WASHER 1"	2
11	9016101	HEX HEAD CAP SCREW 1-8 x 1"	2
12	4950062	MOVABLE JAW	1
13	9240055	SPIROL PIN 3/4" x 4"	1
14	4950649	ADAPTER BLOCK	1
15	4950648	MODIFIED CAISSON JAW	1
16	9240072	SPIROL PIN 1/2" x 3-1/2"	1
17	9030612	LOCKWASHER 1"	2
18	9016137	HEX HEAD CAP SCREW 1-8 x 7"	2
19	4051259	JAW SHIELD	1
20	4051254	JAW SHIELD	1
21	9420004	GREASE FITTING	1
22	9230223	HYDRAULIC ADAPTER 2501-8-12	1
23	9231123	HYDRAULIC ADAPTER 2503-8-12	1
24	9380081	SAFETY CABLE	1
25	9380082	SWEDGE CLAMP	2

## CLAMP BLEEDING PROCEDURE

**NOTICE** Whenever the hydraulic line of the V-8ESC system have been disconnected then reconnected for any reason the two side clamp cylinders and bottom clamp cylinder must be bled of entrained air. In order to effectively bleed all entrained air from the system the hammer must be in the vertical, upright position.

**WARNING** Contents of hydraulic components may be under pressure and extreme care should be taken when opening or bleeding components.

Follow the instructions found in the start-up portion of this manual (pg. 17) to operate the clamp functions. Close the jaws and hold the clamp close function while you open the bleeder on the back of the bottom clamp.

**WARNING** Do not back vent screw all the way out!

Allow oil to vent approximately 30 seconds or until an air free stream of oil comes from each vent screw.

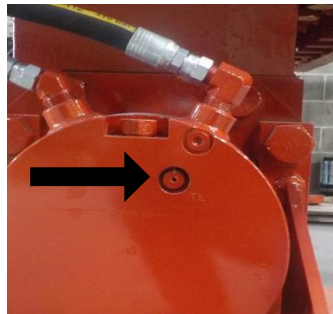

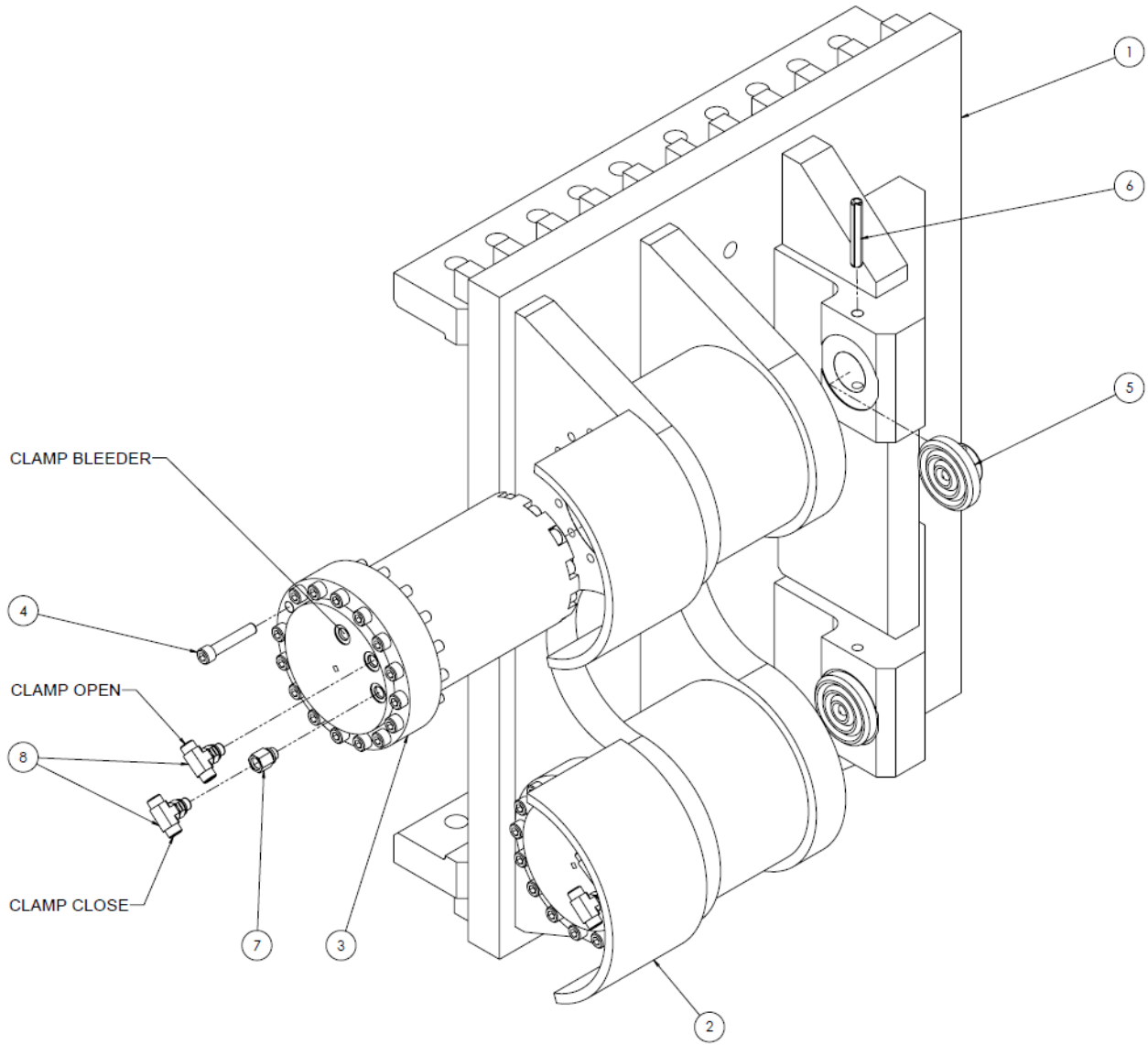

**SIDE CLAMP ASSEMBLY (408 00 33)**

## 43 | DRAWING AND PARTS LISTS

### SIDE CLAMP ASSEMBLY (408 00 33)

ITEM NO.	MKT PART NUMBER	DESCRIPTION	QTY.
1	4080024	SIDE CLAMP MACHINING	1
2	4051237	GUARD - SIDE CLAMP	2
3	4950638	HYDRAULIC CYLINDER	2
4	9050723	SOCKET HEAD CAP SCREW 1/2-13 x 2-3/4"	32
5	4950598	JAW	4
6	9240072	SPIROL PIN 1/2" x 3-1/2"	4
7	9231275	HYDRAULIC ADAPTER 6410-6-6	2
8	9231156	HYDRAULIC ADAPTER 6803-6-6-6	4
9	8100011	STICKER KIT – SIDE CLAMP	1

## CLAMP BLEEDING PROCEDURE

**NOTICE** Whenever the hydraulic line of the V-8ESC system have been disconnected then reconnected for any reason the two side clamp cylinders and bottom clamp cylinder must be bled of entrained air. In order to effectively bleed all entrained air from the system the hammer must be in the vertical, upright position.

**WARNING** Contents of hydraulic components may be under pressure and extreme care should be taken when opening or bleeding components.

Follow the instructions found in the start-up portion of this manual (pg. 17) to operate the clamp functions. Close the jaws and hold the clamp close function while you open the bleeder on the back of the bottom clamp.

**WARNING** Do not back vent screw all the way out!

Allow oil to vent approximately 30 seconds or until an air free stream of oil comes from each vent screw.



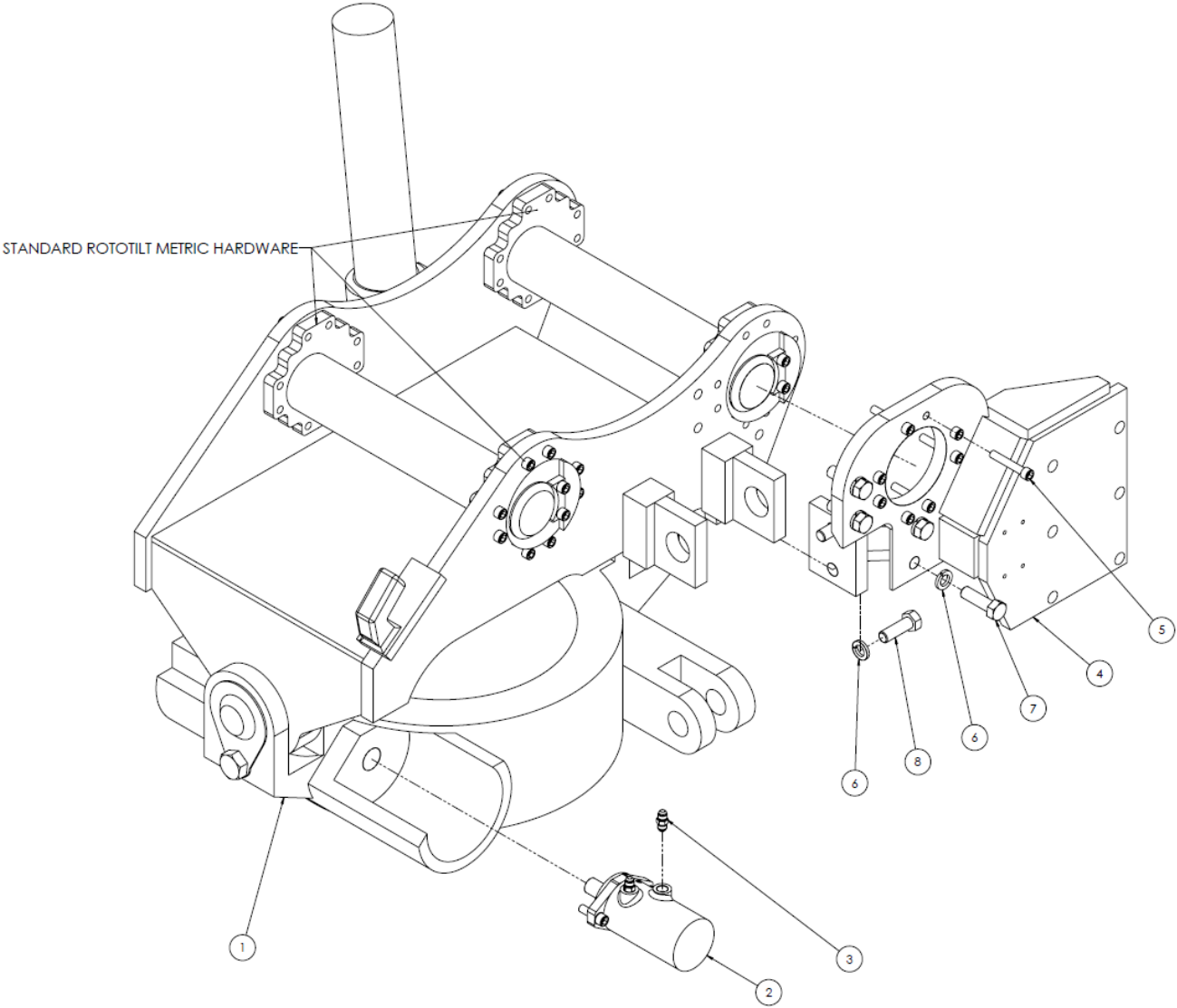

**ROTOTILT ASSEMBLY (408 00 35)**

**ROTOTILT ASSEMBLY (408 00 35)**

<b>ITEM NO.</b>	<b>MKT PART NUMBER</b>	<b>DESCRIPTION</b>	<b>QTY.</b>
1	9220135	ROTOTILT	1
2	4950667	HYDRAULIC MOTOR	1
3	9231408	HYDRAULIC ADAPTER 3800-6-8	2
4	4950678	ESC MANIFOLD MOUNT	1
5	9500147	SOCKET HEAD CAP SCREW M12x1.75 x 75MM	8
6	9030610	LOCKWASHER 3/4"	6
7	9015921	HEX HEAD CAP SCREW 3/4-10 x 2-1/2"	4
8	9015919	HEX HEAD CAP SCREW 3/4-10 x 2-1/4"	2
9	9500143	SOCKET HEAD CAP SCREW M12x1.75 x 300MM	28
10	9500310	DISC LOCK WASHER	28
11	9500009	FLAT WASHER M16	28
12	9500215	HEX NUT M12x1.75	28
13	4020614	HYD. HOSE ASSEMBLY	2
14	4300508	ROTOTILT GREASE LINE	1
15	1170190	CASE DRAIN LINE - ROTOTILT MOTOR	1
16	1170232	BANJO SCREW	2
17	1170240	COPPER WASHER	4
18	9231339	HYDRAULIC ADAPTER 3859-6-6-6	1
19	9231293	HYDRAULIC ADAPTER 3801-6-6	2
20	4110022	NAMERPLATE - CLAMP OPEN	1
21	4110023	NAMEPLATE - CLAMP CLOSE	1
22	4950695	SPIDER CABLE CONVERSION KIT	1

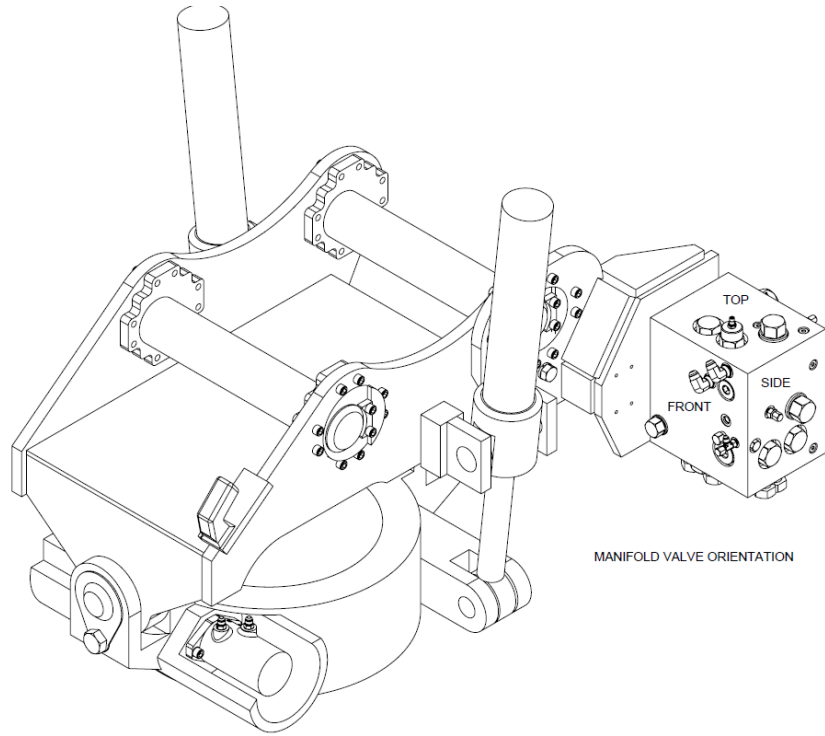

**MANIFOLD VALVE ASSEMBLY (405 12 39)**

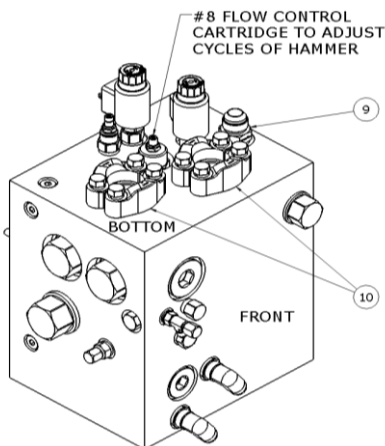
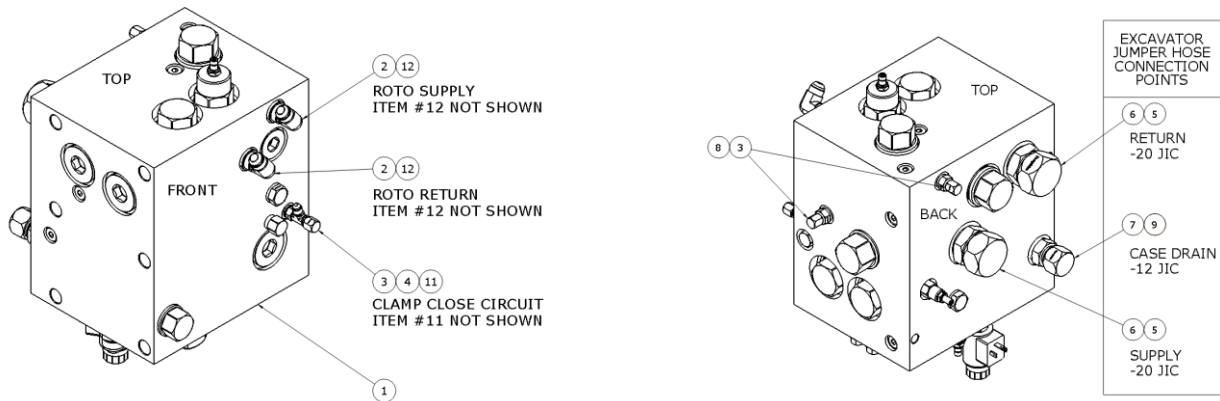

**V-8ESC MANIFOLD ASSEMBLY (405 12 39)**

<b>ITEM NO.</b>	<b>MKT PART NUMBER</b>	<b>DESCRIPTION</b>	<b>QTY.</b>
1	4950634	MANIFOLD VALVE	1
2	9230194	HYDRAULIC ADAPTER 6801-8-8	2
3	9231149	CAP NUT 304-C-4	3
4	9231316	HYDRAULIC ADAPTER 6804-4-4-4	1
5	9230314	HYDRAULIC ADAPTER 6400-20-20	2
6	9230013	CAP NUT 304-C-20	2
7	9230012	CAP NUT 304-C-12	1
8	9231077	HYDRAULIC ADAPTER 6400-4-6	2
9	9230096	HYDRAULIC ADAPTER 6400-12-12	2
10	9230998	SPLIT FLANGE ADAPTER KIT	2

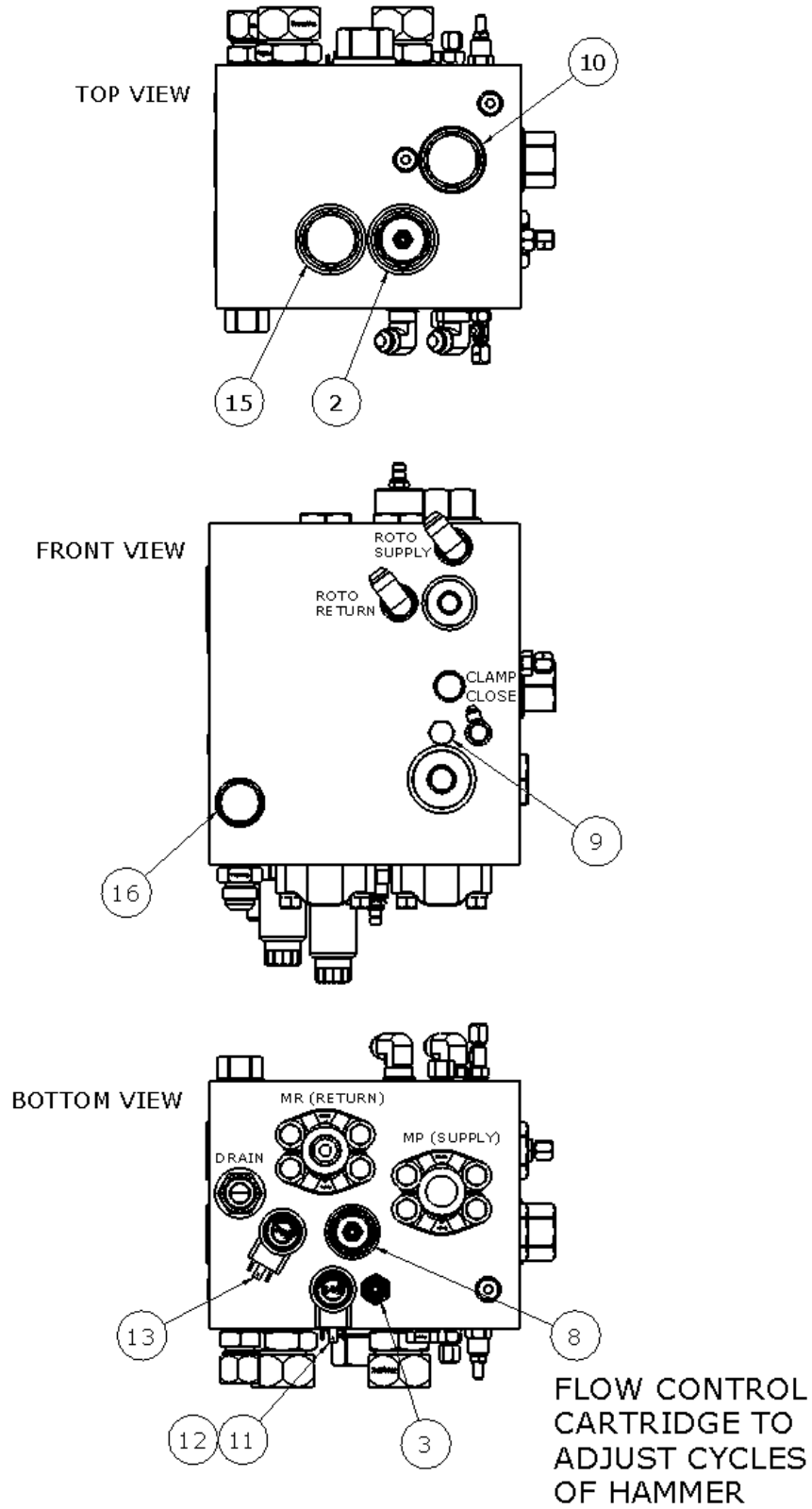

**V-8ESC MANIFOLD COMPONENTS (495 06 34)**

SIDE VIEW

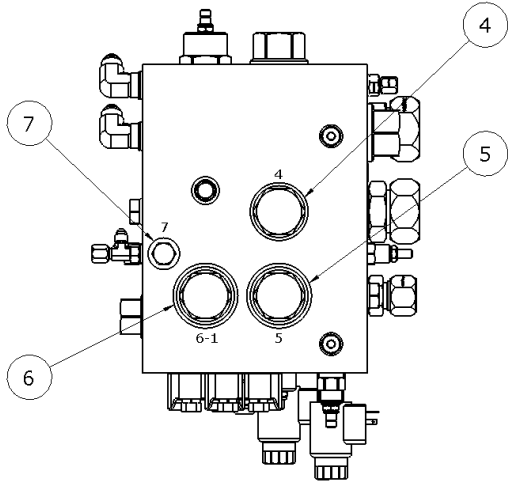

BACK VIEW

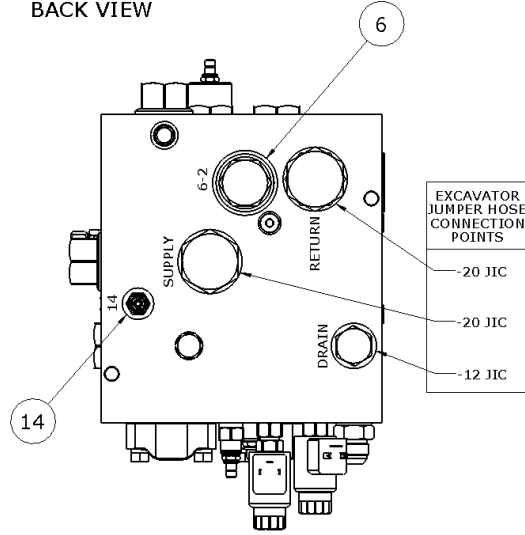

**V-8ESC MANIFOLD COMPONENTS (495 06 34)**

## 51 | DRAWING AND PARTS LISTS

### V-8ESC MANIFOLD COMPONENTS (495 06 34)

ITEM NO.	MKT PART NUMBER	DESCRIPTION	QTY.
1	174-399	MANIFOLD BODY	1
2	9310835	RELIEF VALVE	1
3	9310836	RELIEF VALVE	1
4	9310837	MODULATING VALVE	1
5	9310838	CHECK VALVE	1
6	9310839	CHECK VALVE	2
7	9310840	CHECK VALVE	1
8	9310863	NEEDLE VALVE	1
9	9310841	FLOW CONTROL	1
10	9310842	FLOW CONTROL	1
11	9310843	DIRECTIONAL VALVE	1
12	9310844	DIRECTIONAL SPOOL VALVE	1
13	9310845	DIRECTIONAL SPOOL VALVE	1
14	9310856	RELIEF VALVE	1
15	9310872	CHECK VALVE	1
16	9310724	CHECK VALVE	1

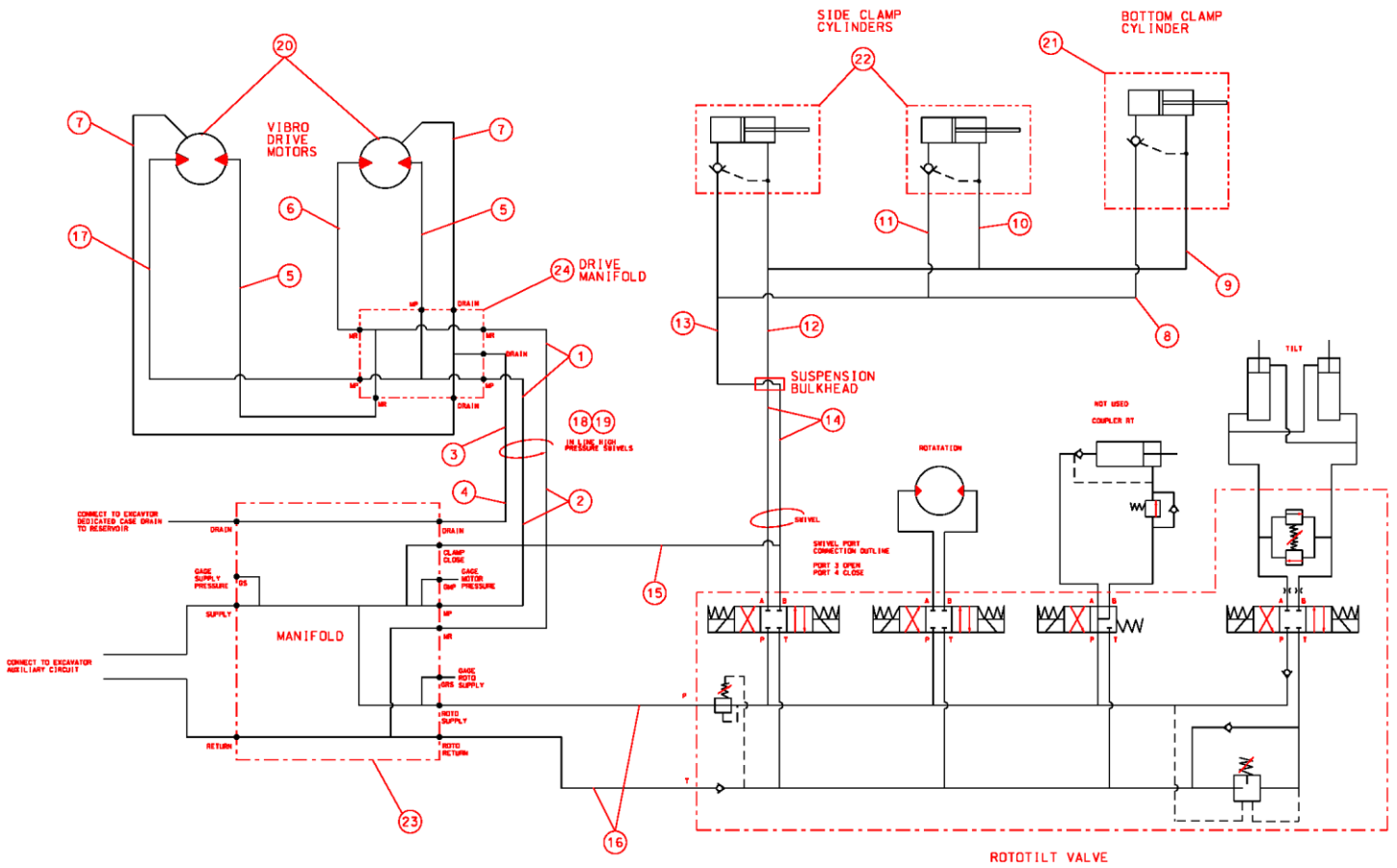

**V-8ESC HYDRAULIC SCHEMATIC AND PARTS LIST**

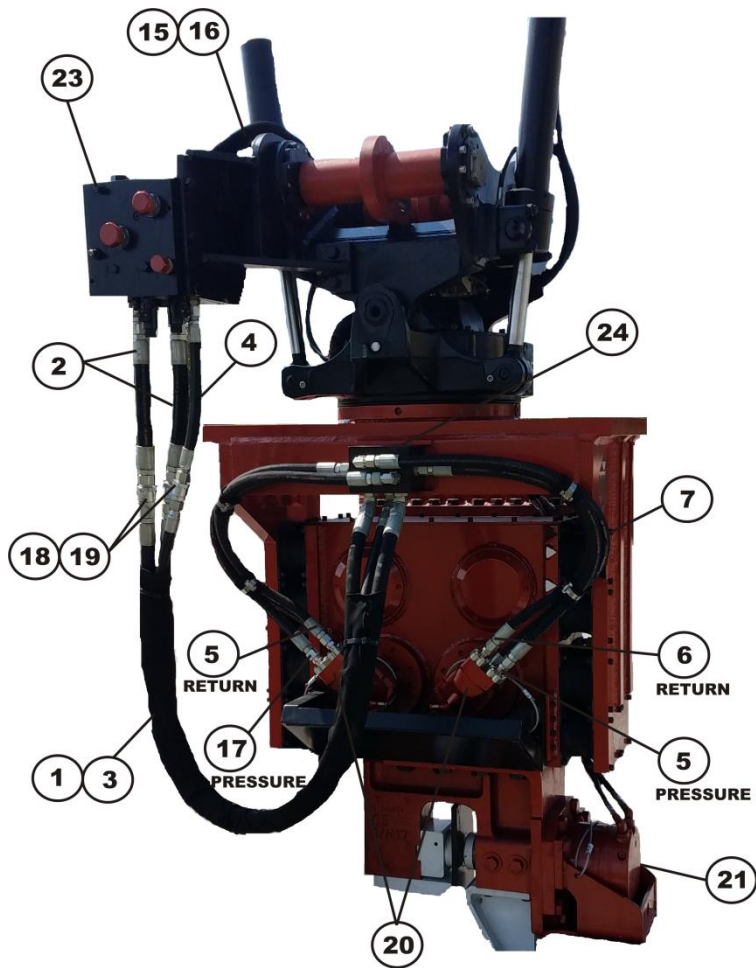
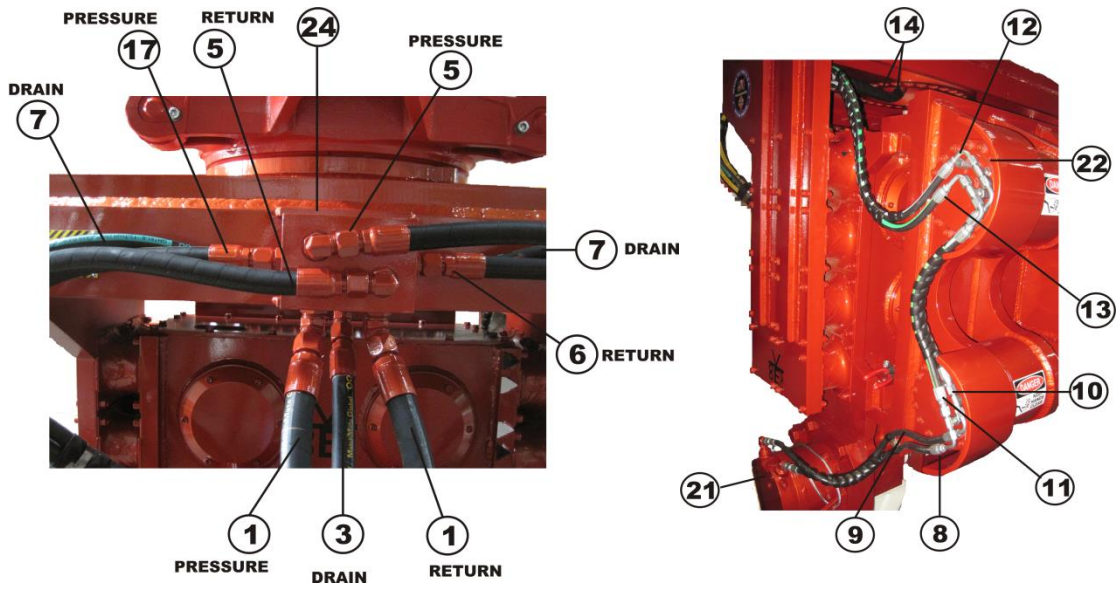

**V-8ESC HYDRAULIC SCHEMATIC AND PARTS LIST**

## V-8ESC HYDRAULIC SCHEMATIC AND PARTS LIST

ITEM NO.	MKT PART NUMBER	DESCRIPTION	QTY.
1	4080039	HYD. HOSE ASSEMBLY	2
2	4080040	HYD. HOSE ASSEMBLY	2
3	4080041	HYD. HOSE ASSEMBLY	1
4	4080042	HYD. HOSE ASSEMBLY	1
5	4080043	HYD. HOSE ASSEMBLY	2
6	4080044	HYD. HOSE ASSEMBLY	1
7	4080045	HYD. HOSE ASSEMBLY	2
8	4080046	HYD. HOSE ASSEMBLY	1
9	4080047	HYD. HOSE ASSEMBLY	1
10	4080048	HYD. HOSE ASSEMBLY	1
11	4080049	HYD. HOSE ASSEMBLY	1
12	4080050	HYD. HOSE ASSEMBLY	1
13	4080051	HYD. HOSE ASSEMBLY	1
14	4080052	HYD. HOSE ASSEMBLY	2
15	4051247	HYD. HOSE ASSEMBLY	1
16	4051270	HYD. HOSE ASSEMBLY	2
17	4061173	HYD. HOSE ASSEMBLY	1
18	9310874	HIGH PRESSURE SWIVEL	2
19	9310875	HIGH PRESSURE SWIVEL	1
20	9100079	HYDRAULIC MOTOR	2
21	4160131	HYDRAULIC CYLINDER	1
22	4950638	HYDRAULIC CYLINDER	2
23	4051239	V-8ESC CONTROL MANIFOLD	1
24	4080057	MOTOR MANIFOLD	1

# 55 | DRAWING AND PARTS LISTS

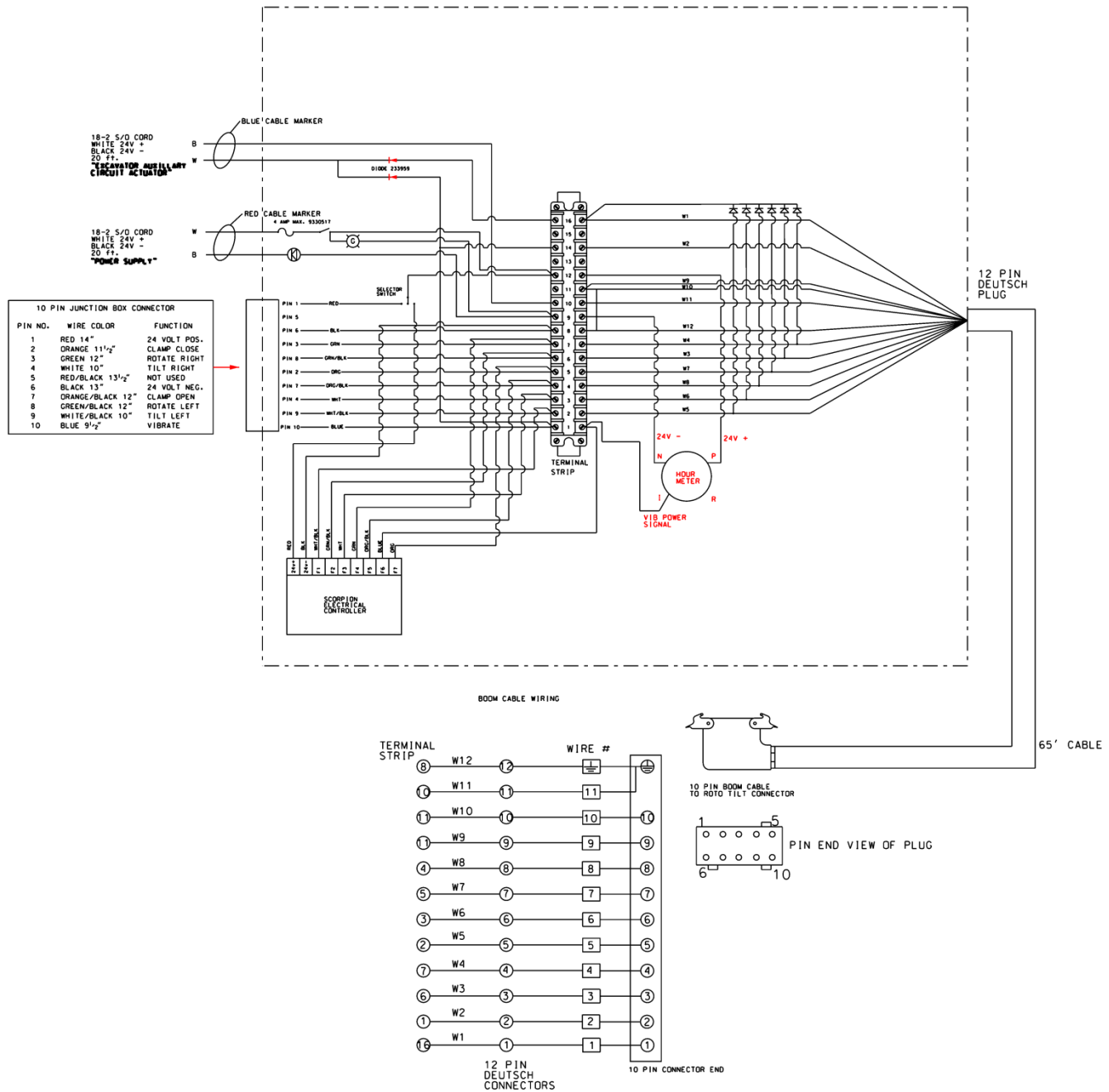

**V-8ESC ELECTRICAL CONTROLS SCHEMATIC**